





A STRUCTURAL FRAMEWORK FOR DISTRIBUTED ELECTRONIC VOTERS REGISTER

 Emmanuel Etuh¹⁺
 Umar Zayyanu²
Onyebuchi Destiny
Jacob³

^{1,2}Department of Mathematics & Computer Science, Arthur Jarvis University,
Akpabuyo, Cross River State, Nigeria

¹Email: emma.etuh@gmail.com

²Email: jacobonyebuchi@gmail.com

³Department of Computer Science, Waziri Umaru Federal Polytechnic,
Birnin-kebbi, Kebbi State, Nigeria.

³Email: zayyanumar1@yahoo.com



(+ Corresponding author)

ABSTRACT

Article History

Received: 22 January 2019

Revised: 4 March 2019

Accepted: 10 April 2019

Published: 28 June 2019

Keywords

Distributed database
Electronic voters' register
Voters Registration
Polling unit
Direct data capturing system
Automated fingerprint
Identification system.

Electronic Voters Register is a key deliverable of the pre-voting stage in an E-voting system that has become a key component of governance in this 21st century. E-voting system is generally grouped into three phases: before-voting, during-voting and after-voting phase. Before-voting handles the enlistment of eligible voters into the voters' database which is a determinant factor for a successful election. Just being enlisted is not a guarantee that a registered voter will participate in an election unless the voter is present at the particular polling unit where the voter registered, on account of change of location, the voter must request for transfer of data to the new location before the election to qualify for voting. So many voters have been disenfranchised due to inevitable relocation which poses a serious challenge in the efficiency of the voters register. This has greatly reduced the total number of eligible voters in the existing system. The Purpose of this research is to design a structural framework that eliminates the hurdles voters go through to become eligible to elect their preferred candidate. Once the Direct Data Capture (DDC) system registers a voter at each polling unit, a locally distributed database across all the registration centers collate and transmit the data to the central database through the States thereby eliminating duplicates from any quarter, redundancy, and need for transfer request as a result of migration. The most suitable approach is the distributed database model that implements a tree data structure for efficient electronic voters register.

Contribution/Originality: The paper's primary contribution in the proposed framework is the eradication of disenfranchisement due to change of location and seamless registration of voters that produces efficient Electronic Voters Register devoid of duplicates thus laying a solid foundation for a transparent E-Voting.

1. INTRODUCTION

The vehicle that ushers in any government in a democratic setting is an election which is done by voting for the candidate of one's choice. There have been so many cons with the manual voting system that has marred the electoral system. E-voting system has been developed in recent times to replace the traditional manual voting system in some countries as seen in literature. According to researchers in this domain, one of the key components of government in the 21st century is Electronic Voting. This method of voting system encourages more participation of eligible voters in the electoral process [1, 2] the future is already here because some developed countries like Australia Belgium, Brazil, Canada Estonia..., United Kingdom are already practicing electronic voting [3] currently in some countries like Estonia, voters are allowed to choose between alternatives of either a card or a mobile phone ID to cast their ballot within a defined period of time. Between 2005 and 2009 that Estonia

introduced the e-voting, almost a quarter of all the votes were cast online [4]. Organization for the Advancement of Structured Information Standard (OASIS) developed a conceptual framework for any e-voting system. The framework comprises of three stages in an election, they are: pre-voting, voting and post-voting stage [5]. According to the stipulated Scope of the I-Voting System in Estonia, "Elections consist of the following principal stages: declaration of elections, registration of candidates, preparation of lists of voters, voting, counting of votes, and announcement of election results" [6].

Common to all E-voting system is the Pre-voting stage and the key activity in pre-voting stage is the preparation of voters' register through registration of voters. To qualify for voting in any election, a candidate must first be registered. Voters' registration is the identification of persons who are eligible to vote in an election and the compilation of a list of all such persons is referred to as a Register of Voters [7, 8]. "The 1999 Constitution of the Federal Republic of Nigeria enshrined that only citizens who have registered as voters and whose names are included in the Register of Voters shall be eligible to vote in an election or referendum" [8].

All citizens of Nigeria who are not less than 18 years, with the requisite eligibility criteria, and wish to be registered as voters must present themselves at designated venues of offices of INEC in their respective wards of each Local Government Areas (LGA) for inclusion in the list called the Register of Voters [9] which is the registration of voters.

For any citizen to be qualified to vote and be voted for, he/she must be a registered citizen. Before a new applicant is registered, eligibility criteria must be met by providing evidence to register as voters to the Registration Officials. "INEC has the legal mandate to register voters and, to maintain and revise the Register of Voters" [7].

Because politics is a game of number, to win election, the candidate must earn the majority of the total votes casted. The law stipulates that "the candidate with the highest number of votes shall be declared as elected by the Returning Officer" [7]. This clue has made potential candidates (politicians) to canvas for multiple registrations in their territories of influence to guarantee their emergence during election.

On the other hand because of political influence and calculations to undo opposition in territories where they have less influence during registration, some registration centers can be rendered inefficient making some eligible voters unable to register within the stipulated period due to the complexity of the system used and ineffectiveness on the side of the registration officers. That was the experience of one woman Merry "Four times I went to the school where registrations were taking place," she told DW. "But they kept sending me away, saying I was too old." She was finally successful at a different registration center. (2019, Nigeria: The challenges of registering to vote).The foundation of any election process is a credible Voters Register. The Voters Register is the basis for determining who is eligible to vote and who is not on Election Day.

There are three types of voters' registration: Periodic Voter Registration, Civil Registry Voter Registration Process, and Continuous Voter Registration" [10]. Periodic Voter Registration requires that a new Register of Voters is prepared just for that election and will be discarded after the election. In Civil Registry Voter Registration, the government automatically integrates information about citizens from the civil register to generate the voters register. In Continuous Voter Registration, the electoral body constantly maintain and update existing voters register for subsequent election.

Before 2006, INEC carried out periodic registration of voters in the period immediately preceding the general elections so as to prepare the Register of Voters before election [7]. But recently, in preparation for the 2019 general election, the commission has employed the Continuous voter registration in other to produce an up-to-date version of the Electronic Voters Register which is presumed to have eliminated the flaw of having duplicate registration of voters.

Recent technologies like the Automated Fingerprint Identification system (AFIS), Smart Card Reader (SCR) and Electronic Voters Register (EVR) have drastically reduced the incidence of multiple registration [9]. But

holistic view will reveal that there are still much duplicated registered voters across different polling units in each wards' Electronic Voters Register. This flaw has defeated the essence of the employed technology because captured details are not integrated; duplicates are inevitable due to so many factors of which this research intends to address.

Some eligible voters are disenfranchised either as a result of loss of their Permanent Voters Card (PVC) or due to change of location before the election as a result of transfer or relocation to a new territory. Once there is a change of location or loss of PVC, a potential vote is lost because effort to retrieve it incurs extreme cost on the voter which discourages them from doing so.

For a voter that lost PVC to get a new one, the voter will have to go through rigorous procedure that in most cases ends in futility. The same applies to a voter that changes location before election that is expected to make a transfer of his data from the old polling unit to the closest one to the current location where the voter resides. These are all the challenges the research intend to address by developing a structural framework for an efficient voters register.

2. REVIEW OF RELATED WORKS

Voters' register is very important in any electoral process. Hence, voter' registration is supposed to be an automatic exercise and should be an exercise done by the Country for all voters as soon as the voter is eligible. In some countries like the United States and France, registration is self-initiated: citizens who wish to vote must register first, and they need to go through this process again each time they move [11]. This same is applicable in Nigeria where voter's registration is more or less a voluntary exercise.

The persons who want to vote need to be registered [12] by an accredited registration officer to be eligible to vote.

The credibility of the elections depends to a great degree on the legitimacy of the voters register, a faulty voters register will ultimately translate into a faulty election. According to a report by Schueller & Wall, Somaliland's first voter registration process between 2008 and 2010 witnessed multiple registrations because "different clans motivated their members to register multiple times in order to augment their numbers and political influence" [13]. The same is witnessed in Nigeria where to fuel their selfish political ambition; the politicians encourage multiple registrations to give them space for rigging during voting. Electoral violence and rigging during elections affect the credibility of the electoral system [14] and that is why they encourage multiple registrations to increase the voters register database for effective cover-up for their rigging plan. Electioneering process normally leads to election fraud such as double registration and other forms of election drawbacks during registration of voters and casting of votes by eligible voters [15].

This has led to an inconsistent and misleading voters' register where the population size is smaller than the number of registered voters. Many a times, elections have been postponed due to many factors, but "one of the challenges that has repeatedly surfaced in negotiations over election dates has been that of establishing a reliable voter register" [13].

Some researchers opined that there's usually a low participation in electoral process by voters when pre-voting registration phase is adopted. "As with many other studies, we have found a highly statistically significant drop in turnout in counties on which registration was imposed compared with counties that had already chosen to use registration" [16]. Others discovered that "self-initiated registration system excludes a large fraction of the citizenry which is otherwise prepared to vote; also lack of information and the cost of going through the administrative registration process are equally important impediments to registration" [11].

But with the introduction of Electronic Voters Register (EVR) and other devices, multiple registration has been eliminated which has greatly reduced the incidence of multiple voting to the barest minimum [9]. The before-voting stage of the Nigeria's 2015 general elections witnessed the use of electronic voters' register, permanent voters' card (PVC) and smart card readers for authentication of voters [2]. The actual ballot casting was still done

manually using Re-Modified Open-Secret Ballot System (REMOBS) [2]. The same was repeated in the 2019 election where actual voting was done manually after accreditation [8]. A well-secured identification and authentication processes for voters through the use of biometrics was developed [2] a private network is required to cast a vote using Direct Recording Electronics (DRE) voting machines connected to the network to a central server. This central server should house the centralized data of all the voters which should be decentralized during the actual period of voting.

Habibu, et al. [12] designed a traditional automated voting system for implementation in Muni University students election using PHP/MySQL platform which is expected to pave way for E-Voting on campus. In their system, the admin handles the registration of both the voters and the aspirants. Khatun, et al. [17] developed an entity-relationship data model for E-voting in their research work titled “Data Modelling for E-Voting System Using Smart Card based E-Governance System” [17]. Leveraging on research works that proposes E-Government System, they narrowed their work to the E-voting system, handling the database aspect.

Mwighusa [15] developed a framework for Biometric Voting System for Tanzania in a paper titled “Transforming Voters Registration Paradigm in Tanzania, The Shift from OMR to BVR. A human fingerprint is unique to each person and can be regarded as a sort of signature, certifying the person's identity [15, 18]. Electronic voters' register contains the details of all eligible voters including a biometric feature [19].

2.1. Review of Voters Register in Nigerian Election Processes

Voters register in Nigeria began with the Manual Register of Voters which was used in the 1988 and 1999 election, “there was nothing like database of voters or any technology introduced to minimize double registrations hence, the voters register used was questionable and was very far from reality in a standard practice” [20]. Because of the flaws observed in the adopted register of voters in 1999 election, the Commission incorporated the computerization of the Register of voters using the Optical Mark Reader (OMR) technology in 2003. But this did not eliminate the problem of multiple registrations, incorrect information of voters, omissions of names, and “ghost” entries, etc. Following the enactment of the Electoral Act 2006, the Commission is now obliged to compile, maintain and update the Register of Voters on a continuous basis [10].

Seventy percent of survey respondents say who are registered had already collected their PVC as of mid-December, compared with 18 percent who had not, 9 percent who have a Temporary Voter Card (TVC), 1 percent who had a PVC but lost it, and 1 percent who have a PVC that needs to be transferred to their current state.(IFES, 2015)

The last registration before the 2015 election incorporated the Optical Mark Reader (OMR) technology and computerization of the voters' register which gave birth to Electronic Voters Register (EVR) that contained a high percentage of voter dislocation as a result of errors in the shading of the OMR forms [1, 20].

Before the 2015 elections, INEC test-ran the SCRs in 12 states of the Federation. Unfortunately, most of the problems encountered during the test run were still experienced during the elections. For instance, some of the card readers broke down and were not able to perform its intended purpose. Others showed blank screens, while others had Subscriber Identification Module (SIM) issues. Even where the card readers worked, and were able to correctly display voter's information from the PVC, verifying voters using their biometrics was very difficult. Yet, in spite of the shortcomings recorded, the use of the SCRs boosted voters' confidence in the electoral processes. Hence, it was not surprising that the number of elections petitions substantially dropped after the elections [21].

In preparation for the 2019 general election, the OMR system for voter registration has been replaced with the Direct Data Capturing (DDC) system. The DDC system for voter registration facilitates direct capture of voters' details, data backup and transfer. This has eliminated the drawback of manual and OMR system giving birth to Electronic Voters Register (EVR). It is a register that contains an updated list of eligible voters in an election. While the Manual Register of Voters used in the 1988 and 1999 election served its purpose, it has become outdated and unusable.

Table 1. List of various technologies deployed by INEC from 1999 to 2016 for registration of voters, accreditation, voting, collation, and transmission of result.

Table-1. Summary of Technology in Electoral processes.

| S/N | Year | Voter Registration | Days for Registration | Data Captured | D-Base | Accreditation /Voting | Result Collation |
|-----|------|---|--------------------------------------|---|--------|---|---|
| 1 | 1999 | Pen/Sheets and Type-writers | 14 Days | Basic details. No picture or finger prints | NIL | NIL | NIL |
| 2 | 2003 | Optical Magnetic Recognition Form (Omr Form) *Automated Finger Prints Identification System (AFIS) | 10 Days | Basic details and finger prints only | YES | NIL | NIL |
| 3 | 2007 | *Direct Data Capture Machine (DDCM) * (AFIS) | 4 Months | Basic details, photograph, and finger prints | YES | Electronic Voters' Register (EVR) | Excel Sheet/E-mail |
| 4 | 2011 | *Direct Data Capture Machine (DDCM) * (AFIS) | 21 Days | Basic details, photograph, and finger prints | YES | Electronic Voters' Register (EVR) | Excel Sheet/E-mail |
| 5 | 2015 | *Direct Data Capture Machine (DDCM) *Improved AFIS/Business Rule. | Continuous Voters Registration (CVR) | Basic details, photograph, and finger prints | YES | * EVR *INEC Voters Authentication System (IVAS)/Smart Card Reader (SCR) | Election Transparency Administration And Collation (e-TRAC) |
| 6 | 2016 | *Direct Data Capture Machine (DDCM) *Improved AFIS/Business Rule. | Continuous Voters Registration (CVR) | Basic details, photograph, and finger prints | YES | * EVR *INEC Voters Authentication System (IVAS)/Smart Card Reader (SCR) | *Electronic-Collation Support (E-Collation) * e-TRAC |
| 7 | 2018 | *Direct Data Capture Machine (DDCM) *Improved AFIS/Business Rule. | Continuous Voters Registration (CVR) | Basic details, photograph, and finger prints | YES | * EVR *INEC Voters Authentication System (IVAS)/Smart Card Reader (SCR) | *Electronic-Collation Support (E-Collation) * e-TRAC |

Source: Toba and Esan [9].

2.2. Method of Registration

Registration is by the use of the Direct Data Capture (DDC) system for voter registration which is currently in practice. The process involves directly capturing the names and other details of voters such as date of birth, gender, address, occupation, photograph, and thumbprints of every voter, using the electronic DDC equipment that stores the information and also prints out the temporary voter's card (TVC) – which is issued to the voter immediately – and entering the same information manually on Form EC. 1A. it is hoped that this approach will achieve minimization or outright elimination of the drawbacks of both the manual and the OMR technology, and thereby produce a credible Register of Voters.

After the period allocated for field compilation, a preliminary Register of Voters (PRV) is printed out and displayed for public scrutiny for a period of not less than five days and not more than 14days. This is to give the public the opportunity to confirm the inclusion of their names and other details in the register, make claims of correction of misspelt names and wrong particulars and of omission, and file objections to the inclusion of names of persons that should not be included in the Register. After the determination of claims and objections, the SRV is

produced and included in the revised Register of Voter which shall be certified by the Commission as the officer register for any election thereafter.

2.3. Existing Electronic Voters Register

For the first time in the history of electioneering process in Nigeria, the 2015 general elections saw the emergence of the use of a combined technology of electronic voters' register, permanent voters' card and smart card readers for authentication of voters [2] these technologies to a large extent eliminated duplication of voters' registration and hence multiple voting in a particular polling unit but that does not stop the voters from having duplicate registrations in other nearby centres.

While the existing Voters register in each polling unit can be adjudged to be efficient and credible, it is not the same if the register is integrated at ward level because each polling unit has been designed to hold its own database, a registrant can actually register in more than one ward. There is a need for a centralized database.

Okediran, et al. [19] said "voters' database system provides reliable, efficient, and effective mechanisms for storing and managing large volumes of voters' information in a multiuser environment [19]. A Nigerian has the right to live in any part of the country. One important advice during voter's registration is that an eligible voter should register at a center nearest to the Ward in which the voter resides. This enables easy access to the polling unit on election day. However, a person who relocated to another place, outside the constituency in which he registered cannot vote in his new location "unless he transfers his registration. Section 13 of the Electoral Act 2010 as Amended provides for Transfer of Registered Voters [10].

This implies that persons displaced as a result of emergency or transfer is disenfranchised except he/she request for a transfer of registration details within a stipulated period of not less than 30 days to the election.

2.4. Procedure for Transfer

Once an eligible registered voter changes address before any election, the voter is considered eligible to vote in the new place of location if the previous records are transferred based on the voter' application which must be within a given period of time before election. The steps registered voters go through to qualify them to vote in electing a candidate just on an account of transfer from the location of registration to avoid disenfranchisement is enormous. Procedure for Transfer as contained in INEC [10] begins with the voter writing an application requesting for transfer with evidence of previous registration. If the application scale through based on INEC's predetermined criteria, the transfer is implemented and the voter is issued a new voter's card.

These steps will be needless if there is an integrated voter's database where INEC can access voters' registration details irrespective of where they registered.

3. STRUCTURAL FRAMEWORK FOR DISTRIBUTED ELECTRONIC VOTERS REGISTER

The Purpose of this research is to develop a structural framework for a distributed electronic voters register that eliminate the hurdles registered voters go through to elect their preferred candidate. Having employed DDC system in the existing system which is very efficient in combating multiple registration at each polling unit, the frame work builds on that to develop a distributed structure that integrate all the Polling Units together thereby eliminating duplicates, redundancy, and need for transfer request as a result of migration. The most suitable structure is a distributed database model that implements a B-tree data structure.

3.1. Data Structure

To represent real life scenario as object in computer memory which will be acted upon by instructions to execute the user's task, data structures are employed. The concept of organizing and storing data in memory to supports efficient access and modification is referred to as data structure [22]. Niklaus Wirth highlighted the

importance of data structure in program development when he said “Algorithms + Data Structures = Programs”. This by implication buttresses the point that if data are efficiently structured, efficiency in application development is imminent. Hence data structure plays a key role in the development of an efficient system which has influenced many designers to use complex data structures [23].

As a result of the ubiquity of computer system interconnection, there are billions of data generated daily which need to be stored efficiently, so there is need for efficient data structure. The Electronic Voters Register data generated by the DDC system from the continuous voters’ registration exercise, if well-structured will eliminate the problem of multiple entries, redundancy, and transfer of records as a result of change in location. The choice of a suitable data structure has direct impact on developed application. Same data structure does not fit different kinds of applications. Design of some data structures are occasioned by the peculiarity of some specific tasks [24]. The application developer has to be guided in their choice of the appropriate data structure to guarantee maximum efficiency of the developed application.

3.1.1. Tree Data Structure

Mehta and Sahni [25] defined data structure as a hierarchical organization of a collection of nodes; it is an abstract data type. The top element which is the root is exactly one, referred to as the root parent. Each subsequent element in the tree has a parent element, and zero or more children elements [22]. Elements are placed inside oval shapes or rectangles and connected by lines to show their relationships, these elements are either parent or children which are interconnected with straight lines that define the relationship.

Different types of tree structure exist. In binary tree there are exactly two children elements from the parent node [25] The two child elements are referred to as the left and right subtrees. Other examples include B+ tree, AVL tree, Red-black tree, Tango tree, Skip list, B-tree. The type of application and its associated operations determines the type of structure that is suitable for implementation.

Data organization witnessed efficiency when tree structures were implemented because they support efficient data access time when compared to linear data structures like arrays or linked lists [26].

The data capturing centers where eligible voters can register are interconnected to a central point and can be conceptually viewed as a family tree. The structural layout of Electronic Voters Register Database depicts an inverted tree structure where the leaves represent the data from each registration center. The registration center in each polling units are linked together to form the data for a particular Ward in a particular Local Government Area, the Local Government Areas aggregate the data from the various Wards in the local government, the States data is the summation of all the Local Government Areas in the State, and the Root aggregates the entire data.

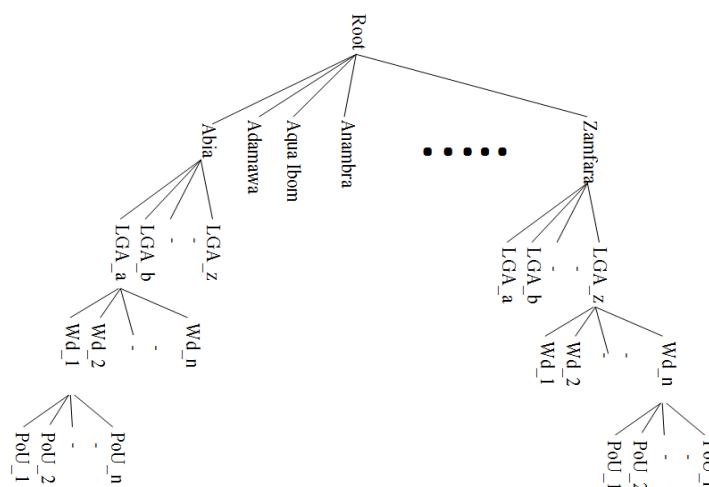

Figure-1. Structural Design of Polling Centers in Nigeria.

3.2. High-Level View of Distributed Electronic Voters Register (DEVVR) System

The system consist of three modules. The first module is the registration module, the second module is the admin module, and the third module is the request. The bidirectional arrows depict the relationships of all the modules.

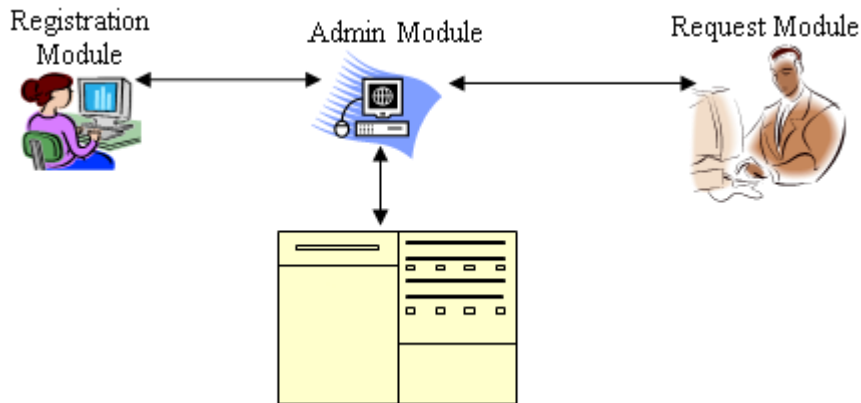

Figure-2. Structure of the Modules for DEVVR system.

3.2.1. Registration Module

The module depicts the various registration centers across the territorial boundary of the election. It implements the E-Voters registration and sends the data to the DEVVR database. Because of the unique voter's registration number and other parameters like data gotten from DDC and AFIS, a single voter cannot register more than once. Any attempt to register in another location will be rebuffed. The registrants ensure that all the criteria of the data structure for the system are met to ensure consistency of the data else, the registration will not be successful.

3.2.2. Admin Module

Manages the entire process be it registration, deleting, and updating, or request for either correction or "change of voters polling unit". Before a request for registration is made, at the setup of the system, the admin sets the rule for inclusion on the registration module to eliminate duplicate in the central database. The registrants' lookup the DEVVR through the Admin for confirmation of every registration of new voter before submission. Every request made either for correction of voter's detail or "change of voters polling unit" to a new location as a result of migration is submitted to the Admin for implementation. At the end of the voters registration exercise, the admin decentralizes the database of voters to each polling unit based on the addresses of each registered voters.

3.2.3. Request Module

Manages the various requests either for "change of voters polling unit" or correction. When the voter's card is issued to a registered voter, request for correction is communicated to the Admin if a voter identifies any human error in keying-in the data during direct capturing of the details. In the case of transfer from the present location before the scheduled election, a request for "change of voters polling unit" to the nearest unit of new residence shall be considered.

3.3. Logical Design

The design shows the conceptual framework for an efficient electronic voters register that eliminate completely data duplication, redundancy and need to request for transfer of details. It is obvious from the design that once a registrant registers at a particular polling unit, the details will be uniquely captured and stored in the centralised Electronic Voters Register Database Management System.

At the root is the centralized Electronic Voters Register (EVR) DBMS that incorporates the integrated database of registered voters for all the states; it is called State Electronic Voters Register (SEVR) which ranges from A to Z. The (SEVR) for each state in turn is the aggregation of all the Local Governments' Electronic Voters Register (LEVR) in that particular State. Each LEVR database will be a collection of all the Ward Electronic Voters Register (WEVR) database of all the Wards in the state. At the top level 1 is the (PEVER) Polling Units Electronic Voters Register that is made up of all the registered voters in that Polling Unit generated by the DDC system for each Polling Unit in the Ward.

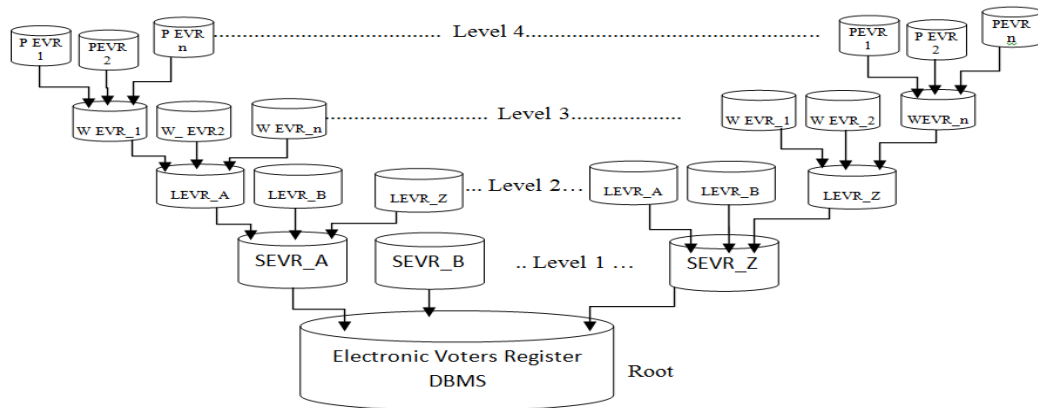

Figure-3. Logical Structure of Electronic Voters Register Database Management System.

3.4. Data Structure

Table-2. Data Structure of Voter's Register.

| Fields | Type | Description |
|------------|---------|--|
| Voters_IdN | Int | Unique key |
| Fa_name | Char | Voter's family name |
| G_name | Char | Voter's given name |
| O_name | Char | Voter's other name(s) |
| Age | Int | Age of the voter |
| Gender | Char | Voter's sex(Male or Female |
| Code_RC | Int | Code number of registration centre |
| Name_RC | Varchar | Name of registration centre |
| Code_RA | Int | The code number of the Registration Area (RA). |
| Name_RA | Varchar | The name of the Registration Area (RA). |
| Code_LGA | Int | The code number of the Local Govt. Area. |
| Name_LGA | Varchar | The name of the Local Govt. Area. |
| Code_St | Int | The code number of the State. |
| Name_St | Varchar | The code number of the State. |
| AFIS_Data | Varchar | Generated biometric data of the voter |

3.5. Process Logic

The logic for the system can be described in three modules of the application

3.5.1. Registration

The process logic for registration of new voter in the DEVR database is given as:

- 1) Start
- 2) Connect to DEVR database
- 3) Search for Voters detail via AFIS_Data
- 4) IF detail is found THEN
 - {
 - Display: You have already registered!
 - }

```
ELSE
    {
        Register the voter by filling all the details and submitting to the DEVR database
    }
5) Stop.
```

3.5.2. Request For Correction of Voter's Details

```
1) Start
2) Get Voters_IdN
3) Connect to DEVR database
4) Search for Voters detail via Voters_IdN
5) IF detail is found THEN
    {
        UPDATE voters record to capture the correct detail
    }
ELSE
    {
        Display: Not found!
        Either your last registration was not successful or you have not yet registered.
        Display: Visit the registration centers to register.
    }
6) Stop.
```

3.5.3. Voters in New Location

```
1) Start
2) Get evidence of new location
3) Get VotersAFIS_Data
4) Connect to DEVR database
5) Search for Voters detail via AFIS_Data
6) IF detail is found THEN
    {
        Fill and submit "change of polling unit" request form
    }
ELSE
    {
        Display: Not found!
        Either your last registration was not successful or you have not yet registered.
        Display: Visit the registration centres to register.
    }
7) Stop.
```

3.5.4. Admin

```
1) Start
2) Get Login details
3) Connect to DEVR database
```

- 4) Check the submitted credential
 IF Details matches the Admin then
 {
 Add new voter
 Delete defunct record
 Approve relocation request form
 Update central database
 }
 ELSE
 {
 You don't have access right to this system!
 }
 5) Stop

4. CONCLUSION

Electronic voters register is crucial to a successful E-voting system. To generate and maintain an efficient voter's register, a structural framework that supports distribution of the database cannot be neglected. Each record set of voters in each polling units can be stored in a hierarchical tree data structure identified with a unique key, thus a voter will not be able to register more than one time. At the end of the registration period just before the voting period, the database for each polling unit is decentralized to each polling unit's local database for actual voting-phase. This structure enhances speed on the overall system since data is decentralized. The admin ensures no duplicate can be stored on the central database during registration. From the central database, each polling units are fed with records of registered voters based on their proximity to the polling units, this produces clear and clean database for each polling units during the voting stage and eliminates the need for request for transfer of voter's record due to change of location. This structure brings perfection in the register of voters, improves the efficiency and clearly enhances a transparent electronic voters' register system that eliminates data duplication, redundancy, and a need to request for transfer of details when one changes location before election as it is currently practiced in the existing system in Nigeria. The government has a lot to do to encourage eligible voters to register by implementing the IT-driven efficient voters register.

Funding: This study received no specific financial support.

Competing Interests: The authors declare that they have no competing interests.

Contributors/Acknowledgement: All authors contributed equally to the conception and design of the study.

REFERENCES

- [1] D. W. Alausa and L. O. Akingbade, "Electronic voting: Challenges and prospects in Nigeria's democracy," *The International Journal of Engineering and Science*, vol. 6, pp. 67-76, 2017.
- [2] O. O. Oladotun and G. A. Rafiu, "A framework for electronic voting in Nigeria," *International Journal of Computer Applications*, vol. 129, pp. 12-16, 2015. Available at: <https://doi.org/10.5120/ijca2015906786>.
- [3] Wikipedia, "Electronic voting." Available: https://en.wikipedia.org/wiki/Electronic_voting. [Accessed January 30, 2019], 2019.
- [4] R. Scammell, "Internet voting a success in two European countries. European University Institute," 2013.
- [5] OASIS, "Election markup language (EML) 4.0a, Organization for the Advancement of Structured Information Standards," 2003.

- [6] Tallinn, *State electoral service of Estonia*. Estonia: General Framework of Electronic Voting and Implementation thereof at National Elections in Estonia, 2017.
- [7] PLAC, *The electoral act 2010 simplified*. Nigeria: Policy and Legal Advocacy Centre, 2015.
- [8] INEC, *Voters registration*. Abuja: Independent National Electoral Commission, 2019.
- [9] P. A. Toba and A. O. Esan, "The impact of ICT in the conduct of election Nigeria," *American Journal of Computer Science and Information Technology*, vol. 6, pp. 1 -6, 2018. Available at: <https://doi.org/10.21767/2349-3917.100014>.
- [10] INEC, *Continous voters registration guide*. Abuja: Independent National Electoral Commission, 2018.
- [11] C. Braconnier, J.-Y. Dormagen, and V. Pons, *Working paper: Voter registration costs and disenfranchisement: Experimental evidence from France*. France: Harvard Business School, 2016.
- [12] T. Habibu, K. Sharif, and S. Nicholas, "Design and implementation of electronic voting system," *International Journal of Computer & Organization Trends*, vol. 45, pp. 1-6, 2017.
- [13] M.-L. Schueller and M. Walls, *Report by international observers on the 2016 voter registration process in Somaliland*. Somaliland: Progressio, 2017.
- [14] A. E. Okwong, "IT-based solutions to the electoral system in Nigeria," *West African Journal of Industrial and Academic Research*, vol. 5, pp. 127-139, 2012.
- [15] D. N. Mwighusa, "Transforming voters registration paradigm in Tanzania, the shift from OMR to BVR," *International Journal of Science and Research*, vol. 4, pp. 1064-1068, 2015.
- [16] S. Ansolabehere and D. M. Konisky, *The introduction of voter registration and its effect on turnout*. Massachusetts Institute of Technology, Political Science. MA: CALTECH/MIT, 2004.
- [17] R. Khatun, T. Bandopadhyay, and A. Roy, "Data modeling for E-voting system using smart card based E-governance system," *International Journal of Information Engineering and Electronic Business*, vol. 9, pp. 45-52, 2017. Available at: <https://doi.org/10.5815/ijieeb.2017.02.06>.
- [18] E. Etuh, A. A. Obinyi, O. S. Yusuf, and O. Akinyele, "A design and implementation of a secure online electronic transaction (SOET) system for a cashless society," *Journal of Computer Sciences and Applications*, vol. 5, pp. 83-89, 2017.
- [19] O. O. Okediran, E. O. Omidiora, S. O. Olabiyisi, R. A. Ganiyu, and O. O. Alo, "A framework for a multifaceted electronic voting system," *International Journal of Applied Science and Technology*, vol. 4, pp. 135 - 142, 2014.
- [20] T. P. Ayeni and A. O. Esan, "The impact of ICT in the conduct of elections in Nigeria," *American Journal of Computer Science and Information Technology*, vol. 6, pp. 1-6, 2018. Available at: <https://doi.org/10.21767/2349-3917.100014>.
- [21] O. Osho, V. L. Yisa, and O. J. Jebutu, "E-voting in Nigeria: A survey of voters' perception of security and other trust factors," presented at the International Conference on Cyberspace Governance: The Imperative for National & Economic Security. Abuja: IEEE, 2015.
- [22] H. C. Thomas, E. L. Charles, L. R. Ronald, and S. Clifford, *Introduction to algorithms* 3rd ed. USA Thomas H. Cormen: Massachusetts Institute of Technology Press, 2009.
- [23] S. Abraham, F. K. Henry, and S. Sudarshan, *Database system concepts*, 6th ed. New York: McGraw-Hill Companies, Inc, 2011.
- [24] LPU, *Fundamentals of data structures. Lovely professional university, directorate of distance education*. Phagwara: Excel Books Private Limited, 2013.
- [25] D. P. Mehta and S. Sahni, *Handbook of data structures and applications*. New York: Chapman & Hall/CRC, 2005.
- [26] T. G. Michael, T. Roberto, and M. H. Goldwasser, *Data structures and algorithms in Java*. USA: John Wiley & Sons, Inc, 2014.

Views and opinions expressed in this article are the views and opinions of the author(s), Journal of Information shall not be responsible or answerable for any loss, damage or liability etc. caused in relation to/arising out of the use of the content.