



FACTORS THAT INFLUENCE PROFITABILITY OF GENERAL INSURANCE ISSUERS IN INDONESIA

Ermy Elisabeth¹⁺
Bambang Mulyana²

^{1,2}Post Graduate Program, Mercu Buana University, Indonesia

¹Email: ermyefoenai@gmail.com

²Email: bambang_mulyana@mercubuana.ac.id



(+ Corresponding author)

ABSTRACT

Article History

Received: 27 November 2018

Revised: 3 January 2019

Accepted: 8 February 2019

Published: 15 April 2019

Keywords

Activity

Liquidity

Solvency

Profitability

General insurance issuers

Regression of panel data.

JEL Classification:

G00; G22; G29.

This research aims to examine and to analyze factors that influence profitability of general insurance issuers in Indonesia. Factors that are examined consist of activity (working capital turnover), liquidity (current ratio), solvency (risk based capital) and profitability (net profit margin, return on investment and return on equity). Research data is quarterly data for five year period (March 2012 to December 2016). The purposive sampling method was used from a population comprising 14 general insurance issuers with outcome of 5 issuers that met the criteria. Using the multiple linear regression method of analysis for panel data, the results revealed that the variables of the working capital turnover, current ratio and risk based capital simultaneously influenced profitability (net profit margin, return on investment, return on equity) while working capital turn over influenced profitability (net profit margin, return on investment and return on equity) only partially. Current ratio also influenced profitability ratio (net profit margin and return on equity) however, Risk Based Capital did not influence all profitability ratios. The results of the study indicate that Insurance companies should increase their sales in order to get a higher working capital, maintain a liquidity ratio and achieve solvency ratio according to the regulations.

Contribution/Originality: This study is one of the first empirical studies to analyze factors that influence profitability of general insurance issuers in Indonesia. The findings of the study reveal such factors and their significance for the insurance companies to earn profitability.

1. INTRODUCTION

The insurance industry is growing very rapidly in Indonesia and is one of the important financial institutions in its financial system. The Indonesian financial system has brought economic order by facilitating, both banking and non-banking financial institutions. For instance, Insurance companies have an interest in both business and individuals because they can fund and compensate other economic sectors putting them in the same position as before the insured event occurred. In addition, they can provide economic and social benefits to the community by preventing losses, reducing anxiety, fear, and increasing employment.

In order to ensure that an insurance company guarantees the interests of its customers, the Indonesian government has issued regulations to regulate the solvency and the liquidity of insurance companies. With the existence of these regulations, the insurance company can now fulfill its obligations to customers. However,

insurance companies also aim to achieve and maintain profits in order to meet the expectations of its shareholders. The only indicator that can suggest whether an insurance company is getting profits is through profitability ratios.

During the 2012-2016 period the average profitability ratio in terms of net profit margin, return on investment and return on equity (NPM, ROA, ROE) fluctuated with a downward trend, as shown in Figure 1. Meanwhile, the factors that support the calculation of profitability fluctuated with an upward trend, as shown in Figure 2 and Figure 3.

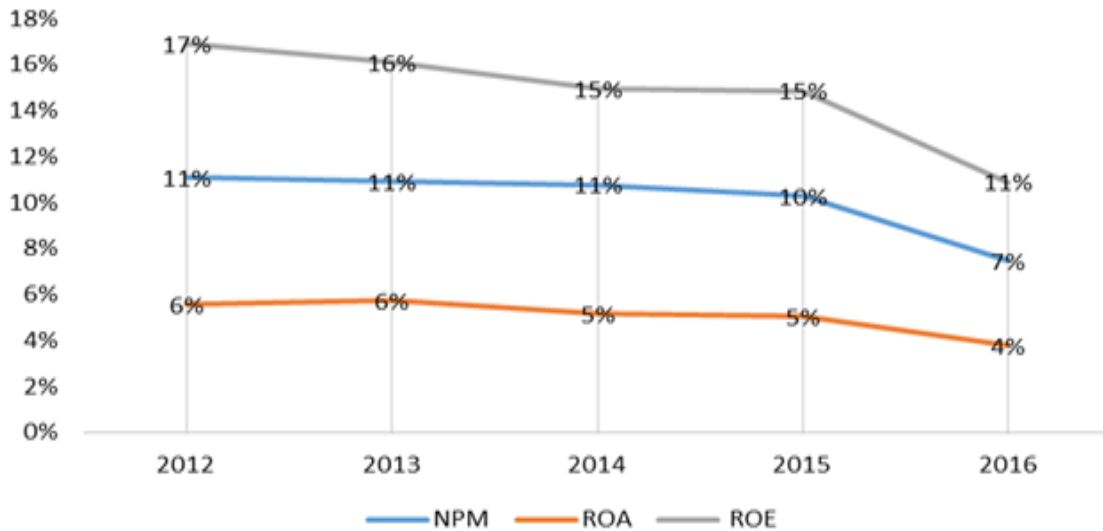

Figure-1. The Trend of Profitability Ratios 2012-2016.

Source: processed by researcher from IDX data base.

Figure 2 also shows that the average of assets (current assets and total assets), liabilities (current liabilities), and equity underwent fluctuation with an upward trending during 2012-2016.

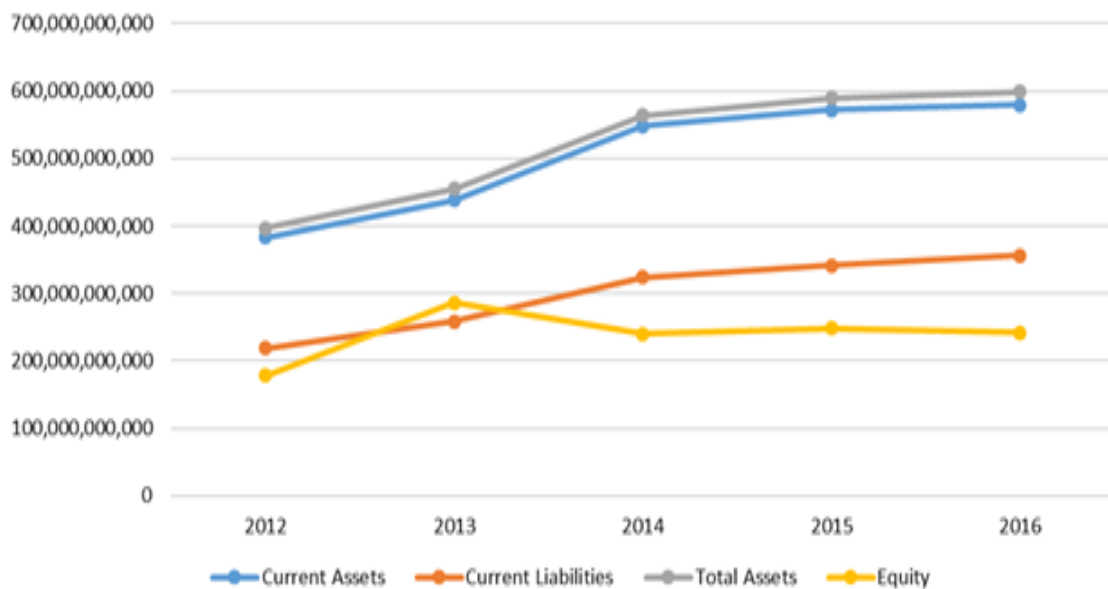

Figure-2. The Trend of Asset, Liability and Equity 2012-2016.

Source: processed by researcher from IDX data base.

Figure 3 also shows that the average of sales (based on receiving gross insurance premium), earnings after tax, and solvency underwent fluctuation with an upward trending during 2012-2016. A slight increase is also noticed in earning after tax and limit of minimum solvency.

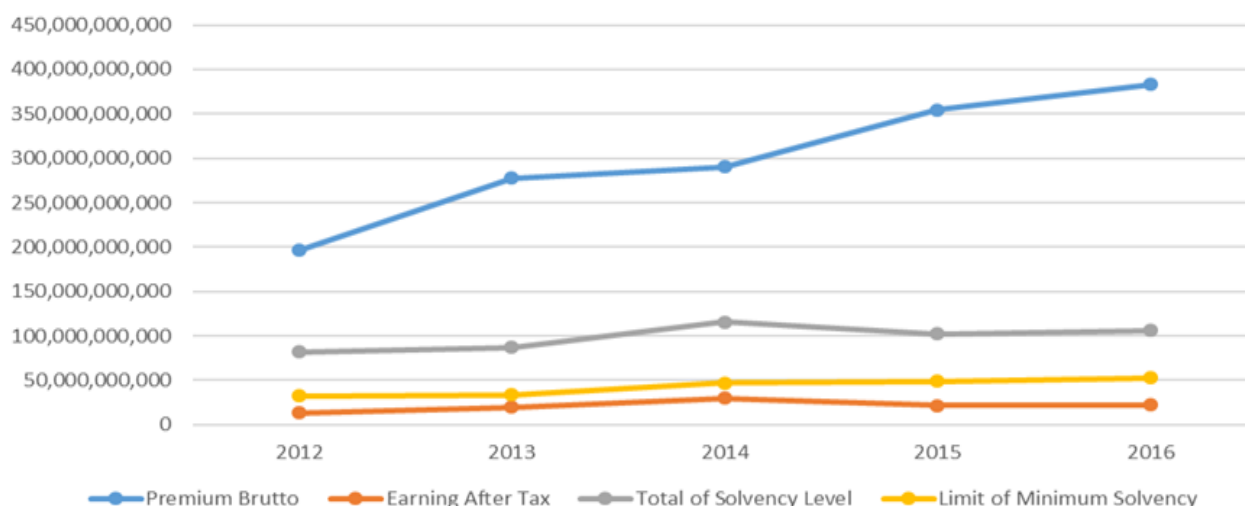

Figure-3. The Trend of Sales, Earnings and Solvency 2012-2016. The Average of Gross Premium, Earning After Tax, Total of Solvency Level, Limit of Minimum Solvency.

Source: processed by researcher from IDX data base.

Based on the phenomenon that profitability ratios of general insurance companies underwent a downward trending, meanwhile factors for calculating the profitability ratios underwent an upward trending, this study aimed to examine the influence of factors (activity, liquidity and solvency) on profitability (NPM, ROI, and ROE).

2. LITERATURE REVIEW

Profitability According to Hirt *et al.* (2011) profitability ratios are used to measure a company's ability to obtain company profits at certain sales levels, asset levels and from shareholders' investments. Thus it can be said that profitability is the amount of net income compared to other financial conditions such as sales, assets, equity of shareholders to rate it as a percentage of some level of activity or investment. The ratios used to measure profitability are Gross Profit Margin, Net Profit Margin, Return on Investment and Return on Equity.

Net Profit Margin It describes the amount of net profit obtained by the company from every sale made. This ratio measures net income after tax on sales. The Formula of Net Profit Margin is:

$$NPM = \frac{\text{Earning after tax}}{\text{Sales}} \times 100\%$$

Return on Investment. Return on Investment or Return on Assets shows the company's ability to generate profits from assets used. This ratio provides a better measure of a company's profitability because it shows the effectiveness of management in using assets to earn income. The formula of Return on Investment is :

$$ROI = \frac{\text{Earning After Tax}}{\text{Total Assets}} \times 100\%$$

Return on Equity. Return on Equity or rentability of equity is a ratio for measuring net income after tax with own capital. Return on Equity measures the ability of a company to obtain profits available to shareholders of the company or to find out the amount of change given by the company on the capital. The formula of Return on Equity is:

$$ROE = \frac{\text{Earning After Tax}}{\text{Equity}} \times 100\%$$

Activity The company's activities in carrying out its operations, in sales, purchasing and other activities can be measured through activity ratio. Every company needs working capital to finance its daily operations. Incoming

funds from sales is issued again to finance the next operation. Thus, the fund will continue to rotate every period during the life of the company. In this study activity of finance is represented by working capital turnover.

Working Capital Turnover (WCT) WCT is a ratio that measures business activity against excess current assets for current liabilities and shows the number of sales that the company can obtain (in Indonesian rupiah) for each rupiah working capital (Sawir, 2001). The ratio of working capital turnover is therefore a comparison between sales and current assets minus current debt. The greater the working capital turnover ratio, the more efficient is the working capital used to finance the company's business activities. In practice, current liabilities in insurance industry are different from current liabilities measured in theory. According to PSAK No.28 about general insurance accounting, there is no difference between current liabilities and long term liabilities as used in a common balance sheet. The formula of working capital turnover is :

$$\text{WCT} = \frac{\text{Sales}}{\text{Current Assets} - \text{Current Liabilities}}$$

Liquidity According to Ross *et al.* (2016) liquidity ratios are ratios that describe a company's ability to fulfill its obligations in the short term. The liquidity ratios are used to analyze the company's liquidity position, namely the current ratio and quick ratio. Regulations concerning the calculation of the liquidity level of the Indonesian insurance companies have been issued by MoF (2004) where the level of liquidity is based on the comparison of current assets with current liabilities. Referring to Infobank (2014) that the determination of the best liquidity ratio standard for insurance companies is equal to or greater than 120%. The formula of liquidity is :

$$\text{Current Ratio} = \frac{\text{Current Assets}}{\text{Current Liabilities}} \times 100\%$$

Solvency According to Harahap (2010) solvency ratios describe the ability of a company to pay its long-term obligations if the company is liquidated. Solvability can be measured by a ratio including debt to equity ratio, and debt to total assets. The limits of the solvency level of insurance companies are regulated in The Ministry of Finance (2003) that insurance companies and reinsurance companies must at any time fulfill a solvability level of at least 120% of the risk of losses that may arise as a result of deviations in the management of assets and liabilities. The calculation of solvency level use the Risk Based Capital (RBC) method based on PER-02 / BL / 2008.

Risk Based Capital is therefore the minimum capital that must be provided by each insurance company or reinsurance company to cover every possible failure to manage its wealth and obligations. The formula of Risk Based Capital is :

$$\text{Risk Based Capital} = \frac{\text{Total Solvency Level}}{\text{Risk-based Minimum Capital}} \times 100\%$$

Framework and Research Hypothesis Since insurance companies' performance is reflected in their liquidity and solvency, it can be stated whether they can meet the clients' obligations for any future claims. . At the same time, insurance companies must make a profit in their business in order to meet shareholders' obligations. Therefore, this study seeks to examine the influence of WCT, CR and RBC to NPM, ROI and ROE. The relationship between independent variables and dependent variables of this study are shown in Figure 4.

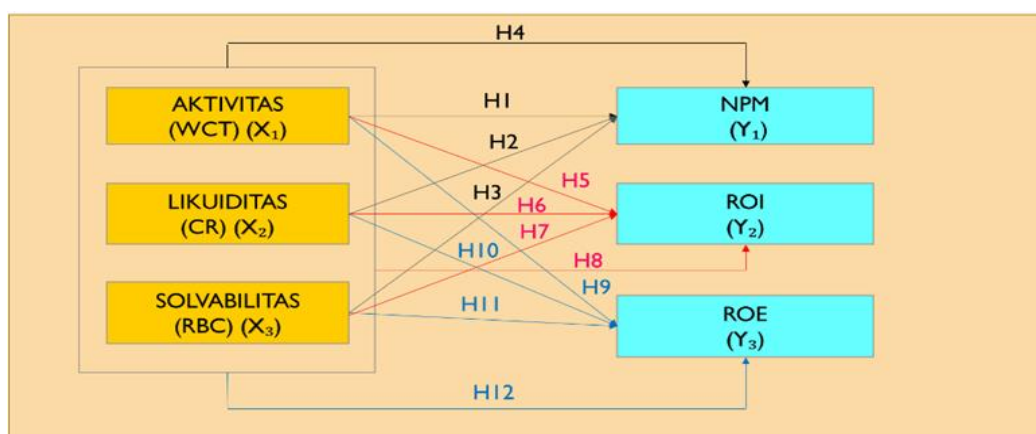

Figure-4. Framework.

Source: developed from previous study.

Hypothesis

Based on the background information, problem statement and framework, the hypotheses used in this study are:

- H₁ : WCT has an influence on NPM
- H₂ : CR has an influence on NPM
- H₃ : RBC has an influence on NPM
- H₄ : WCT, CR, RBC simultaneously have an influence on NPM
- H₅ : WCT has an influence on ROI
- H₆ : CR has an influence on ROI
- H₇ : RBC has an influence on ROI
- H₈ : WCT, CR, RBC simultaneously have an influence on ROI.
- H₉ : WCT has an influence on ROE
- H₁₀ : CR has an influence on ROE
- H₁₁ : RBC has an influence on ROE
- H₁₂ : WCT, CR, RBC simultaneously have an influence on ROE.

3. RESEARCH METHODOLOGY

Type of research This research was carried out by using a quantitative research approach with causal designs that stated causal or influence relationships. The purpose of this study was to find out the profitability (net profit margin, return on investment and return on equity) as the dependent variable, which was stated as influenced by independent variables (working capital turnover, current ratio and risk based capital).

Population and Sample The population in this study was 14 general insurance issuers listed on the Indonesia Stock Exchange (IDX) during the period 2012-2016. The purposive sampling technique was used with certain criteria. The outcome (sample size) was 5 general insurance issuers that met the criteria.

Data and Data Collection Method The type of data used in this study was quantitative secondary data obtained from the Indonesia Stock Exchange (IDX). The techniques of collecting data were documentation or archive techniques. Research data was presented in a panel (time series and cross section).

Data analysis method Data analysis was performed through descriptive statistical tests, followed by model testing, the classic assumption tests (multicollinearity and heteroscedasticity). Other tests performed were multiple linear regression analysis, the significance of the coefficient of determination R test, simultaneous test (F test), partial test (T test).

Model Testing. Model testing was used to determine the best model of the equation of 3 panel data equation models. To determine the models used 2 types of tests i.e. The Chow Test and The Hausman Test are

recommended . The Chow Test is used to choose between Least Square Model and Fixed Effect Model and The Hausman Test is used to choose between the Fixed Effect Model and Random Effect Model.

The Classic Assumption Test. The classic assumption tests used in this study were multicollinearity test and heteroscedasticity test . Multicollinearity test checked whether there is a disturbance on data caused due to the relationships among the independent variables. Heteroscedasticity test checked whether there is a regression disturbances whose variances were not constant across observations.

Regression Analysis Since this study was designed to examine the influence of independent variables on the dependent variable, an analysis model with the least squares equation was used with the equation as follows :

$$Y_i = a + b_1 X_{i1} + b_2 X_{i2} + b_3 X_{i3} + e_i$$

Y_i : *Net Profit Margin / Return on Investment / Return on Equity*

a : Constant

b_1 : Coefficient Regression X_{i1} on Y_i

b_2 : Coefficient Regression X_{i2} on Y_i

b_3 : Coefficient Regression X_{i3} on Y_i

X_{i1} : *Working Capital Turnover*

X_{i2} : *Current Ratio*

X_{i3} : *Risk Based Capital*

e_i : error

The testing level used α (alpha) 5% significance and data processing was performed by Eviews software version 10.

Determination Coefficient Test. Determination Coefficient Test is used to find out the amount of variation in the dependent variable as a result of the variation of independent variables as seen from the R-square value (R^2). The coefficient of determination is between zero (0) and one (1). A small value of R^2 suggests the ability of independent variables to explain variations in the dependent variable is very limited. A value close to 1 suggests that independent variables provide almost all information needed to predict variations in dependent variable. In general, the coefficient of determination for cross data is relatively low because of the large variation between each observation, while time series data usually has a high coefficient of determination.

Restricted F Test (F Test). The F test is used to determine a simultaneous influence of independent variables to dependent variable. The criteria to arrive at such a decision are : if the value of F statistic is more than the value of F table, it suggests that there is an influence of independent variables to dependent variable simultaneously. Adversely, if the value of F statistic is less than the value of F Table, it suggests that there is no influence of an independent variables on dependent variable simultaneously.

T Test. T Test is used to determine the partial influence of independent variables on a dependent variable. The criteria to arrive at such a decision are: if the value of T statistic is more than the value of F table (For positive number), it suggests that there is an influence of independent variables to dependent variable partially; similarly, if the value of T statistic is less than the T Table (for negative number) it also suggests that there is an influence of independent variables on dependent variable partially. Adversely, if the value of T statistic is less than the value of T Table (for positive number), it will suggest that there is an influence of independent variables to dependent

variable partially but if the value of T statistic is more than the value of T Table (for negative number), it will suggest that there is no influence of independent variables on dependent variable partially.

4. RESULT AND DISCUSSION

Descriptive Analysis The results of descriptive statistical calculations describe the mean, median, maximum, minimum and standard deviation of independent and dependent variables. The results are shown in Table 1.

Table-1. Descriptive Statistics.

No	Variable	Mean	Median	Maximum	Minimum	Standard Deviation
1	WCT	1.2115	0.8985	3.5065	0.1449	0.8696
2	CR	1.6411	1.5308	2.5484	1.1823	0.3698
3	RBC	2.4677	2.0374	6.4767	0.07	1.4392
4	NPM	0.1100	0.0799	0.3626	0.0075	0.077
5	ROI	0.0348	0.0289	0.109	0.0016	0.0256
6	ROE	0.0909	0.0823	0.224	0.0046	0.0596

Source: Data processed 2018 by Eviews 10.

Working Capital Turnover (WCT) The average of WCT was found 1.2115 times, which meant that the average effectiveness of WCT was to run the average of companies' businesses 1.2115 times. The minimum value was 0.1449 times and the maximum value was 3.5065 times. The standard deviation of the working capital turnover was 86.96% which was the highest standard deviation between the standard deviations of the other variables This suggests a large distribution of working capital turnover in the sample of the study.

Current Ratio (CR). The average of liquidity ratio (CR) was found 164.11%, which suggests that the average ability of the average of sampled companies to meet their short-term obligations was 164.11%. This value indicated that the average of companies was in a condition of liquidity suggesting that for every 100 IDR the amount of current debt available current assets was 164,11 IDR. The minimum value of the liquidity ratio was 118.23% and the maximum value was 254.84%. The standard deviation of liquidity was 36.98%, indicating that liquidity had a small distribution.

Risk Based Capital (RBC). The average of solvency ratio (RBC) was found 246.77%, suggesting that the average ability of the average of companies to meet their long-term obligations was 246.77%. This value indicated that the average of companies was in a solvent condition, suggesting that it for every 1 IDR debt shown in the capital of the average of companies would guarantee a debt of 2,467 IDR. The minimum value of solvency ratio was 7.00% and the maximum value was 647.67%. The standard deviation of liquidity was 143.92%, which indicates that solvency had a large distribution.

Net Profit Margin (NPM) The average value of the ratio of net profit margin was found 11.00%, suggesting that the ability of the average of companies to get profit based on sales within a period of three months was an average of 11.00%. This also suggested that the average of companies had the ability to generate net income of 0.1100 IDR against every 1 IDR sale. This also suggested that the average of companies was able to generate a net profit that was optimal for the overall costs incurred. The minimum value was 0.75%, indicating that the average of companies got a profit of 0.75 IDR to 1 IDR sale. The maximum value was 36.26%. The standard deviation value of the net profit margin was 7.70%, indicating that the net profit margin had a small distribution.

Return on Investment (ROI). The average value of ROI was found 3.48%. It meant that the ability of the average of companies to generate profits based on total assets in the period of three months averaged 3.48%. This suggests that the average of companies' abilities to generate profits was 3.48 IDR for every 1 IDR asset. The minimum value was 0.16% and the maximum value was 10.90%. The standard deviation value of return on investment was 2.56% which was the lowest standard deviation between the standard deviations of other variables. This indicates that the return on investment had a small distribution.

Return on Equity (ROE). The average value of return on equity was 9.09%, suggesting that the ability of the company to generate profit based on its own capital within a period of three months averaged 9.09%. This meant that the average of companies' abilities to generate profits of 9.09 IDR for own capital, was equal to 1 IDR. The minimum value was 0.46% and the maximum value was 22.40%. The standard deviation value of return on equity was 5.96%, which indicated that solvency had a small distribution.

Multicollinearity Test The result of multicollinearity test was shown in VIF values. If the VIF value is less than 10, there is a clear multicollinearity and vice versa. The result of VIF Values is shown in Table 2.

Table-2. Multicollinearity Test.

Variable	Centered VIF	Result
WCT	1.650309	Multicollinearity Free
CR	1.989630	Multicollinearity Free
RBC	1.290546	Multicollinearity Free
C	NA	

Source: Data processed 2018 by Eviews 10.

Heteroscedasticity Test 1. The Heteroscedasticity Test 1 was performed for Panel Data Equation 1. The result of heteroscedasticity test was shown at Prob-chi squared value. If the Prob-chi squared value is less than 5%, so there is a heteroscedasticity, and vice versa. The heteroscedasticity test of White was shown as the value of Prob chi-squared equal to 0.1080 (10,80%). It meant that there was no heteroscedasticity. The result of Prob Chi-Squared Values is shown in Table 3.

Table-3. Heteroscedasticity Test 1 : White.

Obs*R-squared	Prob. Chi-Square(9)
14.42608	0.1080

Source: Data processed 2018 by Eviews 10.

The Chow Test 1 the Chow Test is used to select between pooled least square model and fixed effect model. From the chow test, one can generate the best model to explain the equation of panel data. The Chow Test 1 was performed for Panel Data Equation 1. The selection of the model was based on the comparison between the value of F statistic and the value F Chow table. If the value of F statistic is more than the value of F Chow table, the preferred model is Fixed Effect Model, and vice versa. The Value of F statistic was 6.861048 meanwhile the value of F Chow Table was 2.970, so the preferred model was The Fixed Effect Model for this study. The result of The Chow Test is shown in Table 4.

Table-4. The Chow Test 1.

Effects Test	Statistic	d.f.	Prob.
Cross-section F	6.861048	(4,92)	0.0001
Cross-section Chi-square	26.106067	4	0.0000

Source: Data processed 2018 by Eviews 10.

The Hausman Test 1 the Hausman Test is used to select between Random Effect Model and Fixed Effect Model. The Hausman Test 1 was performed for Panel Data Equation 1. The selection of the model is done by comparing the value of Chi Squared statistic with the value Chi squared table. If the value of Chi square statistic is more than value of chi square table, the preferred model is Fixed Effect Model, and vice versa. The Value of Chi square statistic was 14.086412 meanwhile the value of Chi Square Table was 7.815, so the preferred model was The Fixed Effect Model. The result of the Hausman Test is shown in Table 5.

Table-5. The Hausman Test 1.

Test Summary	Chi-Sq. Statistic	Chi-Sq. d.f.	Prob.
Cross-section random	14.086412	3	0.0028

Source: Data processed 2018 by Eviews 10.

Panel Data Equation 1 Based on the result of the modelling tests (the Chow test and the Hausman test), the preferred model for panel data equation was The Fixed Effect Model. Table 6 is the summary of the result of The Fixed Effect Model for the panel data Equation 1.

Table -6. The Result of Panel Data Equation 1, Dependent Variable : NPM.

Variable	Coefficients	t-statistics	P-Value	Remark
C	0.088808	5.457329	0.0000	-
WCT (X_1)	-0.004520	-2.688595	0.0085	Significant
CR (X_2)	0.023552	2.920465	0.0044	Significant
RBC (X_3)	-0.001302	-1.278728	0.2042	Not Significant
R-Squared	= 0.701599			
Adjusted R-squared	= 0.678895			
F-statistic	= 30.90145			
Prob(F-statistic)	= 0.000000			

Source: Data processed 2018 by Eviews 10.

According to Table 6 the result of panel data Equation 1 is as follows:

$$\text{NPM} = 0.088808 - 0.004520 \text{ WCT} + 0.023552 \text{ CR} - 0.001302 \text{ RBC} + e_i$$

The Coefficient Determination (R^2) Result Coefficient Determination represents how much the ability of the independent variables can influence the dependent variable. The value of coefficient determination used is the value of Adjusted R-Square. Based on the result of Adjusted R-Squared the value is 0.678895 or 67,8895%. It meant that WCT, CR and RBC simultaneously could influence NPM as well as other variables.

The F Test Result. The Value of Prob F Statistic represents how good is the model which is used. If the value of Prob F Statistic is less than significant 5%, it means that the model is feasible. Based on the result of the value of Prob F Statistic as 0.000000, which is less than 5%, it suggests that it was suitable. The value of F statistic determines whether all the independent variables simultaneously influence the dependent variable. If the value F statistic is less than the value of F table, it means that all independent variables do not influence the dependent variable, and vice versa. Based on the F statistic result, it is shown (30.90145) that the value of F statistic was more than the value of F table, which was 3.091. It suggests that WCT, CR, RBC, simultaneously influenced NPM.

The T Test Result. The T Test is used to determine whether independent variables influenced dependent variable partially. If the value of t statistic is more than the value of t table (for positive value) the independent variable influences the dependent variable, and vice versa. For negative value, the parameter of decision making depends on the value of statistic: if the value of statistic is less than the value of t table, the independent variable influences the dependent variable, and vice versa.

The result of T test are as follows:

- Working Capital Turnover (WCT). Based on the result, the P value was 0.0085 (less than 5%), the value of t statistic was -2.688595 (more than the value of t table, -1,985) and the coefficient was -0.004520. It suggests that WCT was significant and had negative influence on NPM. According to Salombe *et al.* (2017) the inefficient and ineffective WCT is caused by the influence of liquidity to cover total liabilities. In other words, liquidity in insurance companies is high enough to cover the total liabilities and thus can make WCT inefficient and ineffective. The higher liquidity to cover the liabilities will make the value of WCT become smaller. These results are unique as no previous study has obtained similar results.

- b. Current Ratio (CR). The P Value was found 0.0044 (less than 5%), the value of t statistic was 2.920465 (more than the value of t table 1,985) and the coefficient was 0.023552. It suggests that CR was significant and had a positive influence on NPM. These results are unique as no previous study has obtained similar results.
- c. Risk Based Capital (RBC). The P value was 0.2042 (more than 5%), the t statistic value was -1, 278728 (more than the value of t table 1,985) and the coefficient was -0.001302. It suggests that RBC was not significant and had no influence on NPM. The result of this study is in line with the prior research by Mulyana and Elisabeth (2018) which also found that solvency (RBC) did not have any influence on NPM.

Heteroscedasticity Test 2. The Heteroscedasticity Test 2 was performed for Panel Data Equation 2. The heteroscedasticity test of White showed that the value of Prob chi-squared was 0.08030 (8,03). The value of Prob Chi-Squared was more than 5%, so there was no heteroscedasticity. The result of Prob Chi-Squared Values is shown in Table 7.

Table-7. Heteroscedasticity Test 2: White.

Obs*R-squared	15.40820	Prob. Chi-Square(9)	0.0803
---------------	----------	---------------------	--------

Source: Data processed 2018 by Eviews 10.

The Chow Test 2. The Chow Test 2 is used to select between pooled least square model and fixed effect model for panel data Equation 2. The Value of F statistic was 7.406153 while the value of F Chow Table was 2.970 , so the preferred model was The Fixed Effect Model. The result of The Chow Test 2 is shown in Table 8.

Table-8. The Chow Test 2.

Effects Test	Statistic	d.f.	Prob.
Cross-section F	7.406153	(4,92)	0.0000
Cross-section Chi-square	27.915077	4	0.0000

Source: Data processed 2018 by Eviews 10.

The Hausman Test 2. The Hausman Test 2 is to select between Random Effect Model and Fixed Effect Model for panel data Equation 2. The Value of Chi square statistic was 11.954616 while the value of Chi Square Table was 7.815, so the preferred model was The Fixed Effect Model. The result of The Hausman Test is shown in Table 9.

Table-9. The Hausman Test 2.

Test Summary	Chi-Sq. Statistic	Chi-Sq. d.f.	Prob.
Cross-section random	11.954616	3	0.0075

Source: Data processed 2018 by Eviews 10.

Panel Data Equation 2. Based on the result of the modelling tests (The Chow Test and The Hausman Test), the preferred model for panel data equation was Fixed Effect Model. Table 10 is the summary of Fixed Effect Model for Panel Data Equation 2.

Table-10. The Result of Panel Data Equation 2, Dependent Variable : ROI.

Variable	Coefficients	t-statistics	P-Value	Remark
C	-0.046696	-1.917659	0.0583	-
WCT (X ₁)	0.011339	5.440149	0.0000	Significant
CR (X ₂)	0.039715	2.626668	0.0101	Significant
RBC (X ₃)	0.001192	0.947990	0.3456	Not Significant
R-Squared	= 0.504678			
Adjusted R-squared	= 0.466990			
F-statistic	= 13.39110			
Prob(F-statistic)	= 0.000000			

Source: Data processed 2018 by Eviews 10.

According to Table 10 the result of Panel Data Equation 2 is as follows :

$$ROI = -0.046696 + 0.011339WCT + 0.039715CR + 0.001192 + e_i$$

The Coefficient Determination (R²) Result Based on the result of Adjusted R-Squared above, it is 0.466990 or 46.6990%. It suggests that WCT, CR and RBC simultaneously influenced NPM with 46.6990 % as well as the other variables that were not studied.

The F Test Result. Based on the result, the value of Prob F Statistic is 0.000000, which is less than 5%, so it was suitable to be used. Based on the F statistic result, it was shown (13.39110) that the value of F statistic was more than the value of F table, which was 2.970. It suggested that WCT, CR, RBC, simultaneously influenced ROI.

The T Test Result. The results of t test are as follows:

- a. Working Capital Turnover (WCT). Based on the result, the P value was 0.0000 (less than 5%), the value of t statistic was 5.440149 (more than the value of t table was 1,985) and the coefficient was 0.011339. It meant that WCT was significant and had a positive influence on ROI. These results are unique as no previous study has obtained similar results..
- b. Current Ratio (CR). The P Value was found 0.0101 (less than 5%), the value of t statistic was 2.626668 (more than the value of t table 1,985) and the coefficient was 0.039715. It suggested that CR was significant and had positive influence on ROI. The result of this study was in accordance with the research by Charumathi (2012) suggesting that CR was significant and had a positive influence on ROA . Other studies consistent with these results are Daare (2016) who found that liquidity was significant and had a positive effect on ROA and Bawa and Chattha (2013) whose study revealed that liquidity influenced ROA significantly.
- c. Risk Based Capital (RBC). The P value was found 0.3456 (more than 5%), the t statistic value of RBC was 0.947990, and the coefficient was 0.001192. It suggested that RBC did not influence ROI. The result of this study are in accordance with Rahayu and Mubarak (2017) and Mulyana and Elisabeth (2018) who also found that solvency (RBC) did not significantly influence ROI.

Heteroscedasticity Test 3. The Heteroscedasticity Test 3 was performed for Panel Data Equation 3. The heteroscedasticity test of White was shown that the value of Prob chi-squared was 0.1512 (15.12%). The value of Prob Chi-Squared was more than 5%, so there was no heteroscedasticity. The result of Prob Chi-Squared Values is shown in Table 11.

Table-11. Heteroscedasticity Test 3 : Glesjer.

Obs*R-squared	5.298259	Prob. Chi-Square(3)	0.1512
---------------	----------	---------------------	--------

Source: Data processed 2018 by Eviews 10.

The Chow Test 3. The Chow Test 3 is used to select between pooled least square model and fixed effect model for panel data Equation 3. The Value of F statistic was 6.307162 while the value of F Chow Table was 2.970 , so the preferred model was The Fixed Effect Model. The result of The Chow Test 3 is shown in Table 12.

Table-12. The Chow Test 3.

Effects Test	Statistic	d.f.	Prob.
Cross-section F	6.307162	(4,92)	0.0002
Cross-section Chi-square	24.233772	4	0.0001

Source: Data processed 2018 by Eviews 10.

The Hausman Test 3. The Hausman Test 3 is to select between Random Effect Model and Fixed Effect Model for panel data Equation 3. The Value of Chi square statistic was found 22.864669 while the value of Chi Square Table was 7.815 , so the preferred model was The Fixed Effect Model. The result of The Hausman Test 3 is shown in Table 13.

Table-13. The Hausman Test 3.

Test Summary	Chi-Sq. Statistic	Chi-Sq. d.f.	Prob.
Cross-section random	22.864669	3	0.0000

Source: Data processed 2018 by Eviews 10.

Panel Data Equation 3. Based on the result of the modelling tests (the chow test and the Hausman test), the preferred model for panel data equation was Fixed Effect Model. Table 14 is the summary of Fixed Effect Model for the panel data of Equation 3.

Table-14. The Result of Panel Data of Equation 3, Dependent Variable : ROE.

Variable	Coefficients	t-statistics	P-Value	Remark
C	-0.004162	-0.073975	0.9412	-
WCT (X_1)	0.047876	9.941763	0.0000	Significant
CR (X_2)	0.023904	0.684292	0.4955	Not Significant
RBC (X_3)	0.000150	0.051492	0.9590	Not Significant
R-Squared	= 0.593545			
Adjusted R-squared	= 0.562619			
F-statistic	= 19.19250			
Prob(F-statistic)	= 0.000000			

Source: Data processed 2018 by Eviews 10.

According to Table 14 the result of panel data Equation 3 is as follows:

$$\text{ROE} = -0.004162 + 0.047876\text{WCT} + 0.023904\text{CR} + 0.000150\text{RBC} + e_i$$

The Coefficient Determination (R^2) Result Coefficient Determination represents of the extent to which independent variables influence the dependent variable. The value of coefficient determination used is the value of Adjusted R-Square. Based on the result of Adjusted R-Squared above was 0.562619 or 56.2619%. It suggests that WCT, CR and RBC simultaneously can influence ROE as well as other variables that were not studied.

The F Test Result. The result of the value of Prob F Statistic at 0.000000 was less than 5%, which was suitable. Based on the F statistic result, it was shown (19.19250) that the value of F statistic was more than the value of F table, which was 2.970. It suggested that WCT, CR, RBC, simultaneously influenced ROE.

The t Test Result the results of t test are as follows:

- Working Capital Turnover (WCT) Based on the result, the P value was found 0.0000 (less than 5%) the value of t-statistic was 9.941763 (more than the value of t-table 1,985), and the coefficient was 0.047876. It suggested that WCT was significant and had positive influence on ROE. The result of this study is in line with the research by Mulyana and Elisabeth (2018) who also found that the efficient of WCT had an influence on ROE.
- Current Ratio (CR). The P Value was 0.4955 (more than 5%), the value of t-statistic was 0.684292 (less than the value of t-table 1,985) and the coefficient was 0.023904. It suggested that CR was not significant and did not influence ROE. The result of this study is in accordance with the research by Jibrán *et al.* (2016) that CR is not significant and has no an effect on ROE. Another study with the same result is Mulyana and Elisabeth (2018) which also found that liquidity had no effect on ROE.
- Risk Based Capital (RBC). The P value was 0.9590 (more than 5%), the t- statistic value of RBC was 0.051492 (less than the value of t table 1,985), and the coefficient was 0.000150. It suggested that RBC did not influence ROE. The result of this study is in accordance with the research by Leviany and Wiwin (2014) which suggests that RBC had no influence on ROE. Other study consistent with these findings are Rahayu and Mubarak (2017) and Mulyana and Elisabeth (2018) which also revealed that solvency (RBC) did not have significant influence on ROE.

5. CONCLUSION AND SUGGESTIONS

Based on the result of the study, the following are the conclusions:

1. The Independent variables (WCT, CR, RBC) simultaneously had an influence to profitability ratio (NPM). It could be concluded that the change in the level of net profit margin was influenced by activity (WCT), liquidity (CR) and solvency (RBC). The result in this study is in accordance with [Mulyana and Elisabeth \(2018\)](#) which also found that the efficient working capital turn over, liquidity and solvency had an influence on NPM.
2. The Variable of Activity (WCT) partially had a negative and significant influence to the net profit margin. These results indicated that the higher the activity (WCT), the lesser would be the net profit margin. It could be concluded that the change in the level of net profit margin was influenced by the level of activity (WCT) in general insurance companies.
3. The variable of liquidity (CR) partially had a positive and significant influence on the net profit margin. These results indicated that the higher the liquidity (CR), the greater will be the net profit margin. It could be concluded that the change in the level of net profit margin was influenced by the level of liquidity in the general insurance company.
4. The variable of solvency (RBC) partially had no influence on the profit margin and it was not significant either. These results indicated that the higher the liquidity (CR), the greater would be the net profit margin. It could be concluded that the change in the level of net profit margin was influenced by the level of liquidity in the general insurance company. This result is in accordance with [Mulyana and Elisabeth \(2018\)](#) which also suggested that solvency (RBC) had no influence on the net profit margin.
5. The independent variables (WCT, CR, RBC) simultaneously had an influence on profitability ratio (ROI). It could be concluded that the change in the ROI level was influenced by activity (WCT), liquidity (CR) and solvency (RBC). This result is in accordance with [Mulyana and Elisabeth \(2018\)](#) which also suggested that efficiency of working capital turnover, liquidity and solvency (RBC) had an influence on ROI.
6. Variable of activity (working capital turnover) partially had a positive and significant influence on ROI. These results indicated that the higher the activity (WCT), the greater would be the return on investment. It could be concluded that the change in the level of return on investment was influenced by the level of activity (WCT) in general insurance companies.
7. Variable of liquidity (CR) partially had a positive and significant influence on the return on investment. This result indicated that the higher the liquidity (CR), the greater would be the return on investment. It could be concluded that the change in the level of return on investment was influenced by the level of liquidity (CR) in general insurance companies. This result is in accordance with the research by [Charumathi \(2012\)](#) by [Daare \(2016\)](#) and by [Bawa and Chattha \(2013\)](#) which also suggest that liquidity influenced ROA.
8. The variable of solvency (RBC) partially had no influence on the return on investment (ROI) and it was not significant either. This result is in accordance with by [Rahayu and Mubarak \(2017\)](#) and [Mulyana and Elisabeth \(2018\)](#) which also suggested that solvency (RBC) had no influence on the return on investment.
9. The independent variables (WCT, CR, RBC) simultaneously had an influence on profitability ratio (ROE). It could be concluded that the change in the ROE level was influenced by activity (WCT), liquidity (CR) and solvency (RBC). This study is in accordance with [Mulyana and Elisabeth \(2018\)](#) which also suggested that efficient WCT, liquidity and solvency (RBC) had an influence on ROE.
10. The variable of activity (WCT) partially had a positive and significant influence on ROE. This result indicated that the higher the activity (WCT), the greater would be the return on equity. It could be concluded that the change in the level of return on equity was influenced by the level of activity (WCT) in

general insurance companies. This result is in accordance with Mulyana and Elisabeth (2018) which also suggests that efficiency of working capital turnover has an influence on the return on equity.

11. Variable of liquidity (CR) partially had no influence on the return on equity and it was not significant either. This result is in accordance with Mulyana and Elisabeth (2018) which also suggests that liquidity has no an influence to the return on equity.
12. The variable of solvency (RBC) partially had no influence to the return on equity and it was not significant either. This result is in accordance with the research by Levianny and Wiwin (2014); Rahayu and Mubarak (2017) and Mulyana and Elisabeth (2018) which also suggest that solvency (RBC) had no influence on the return on equity.

As the implication of this study, the following suggestions can be given

1. Insurance companies' managements should drive marketing forces in order to increase the sales so that the companies could get a higher working capital that can be rotated to finance their next operations.
2. Insurance companies' managements should maintain a liquidity ratio where the average liquidity ratio achieved is above the standard value according to Infobank magazine version, which shows that the company can fulfill its short-term obligations.
3. Insurance companies' managements should maintain solvency ratio (RBC) as written in the regulations from the authority, although result of this study show that RBC does not influence all profitability ratios. The achievement of the RBC ratio as a standard is 120%. It can indicate that the companies are in a solvent condition. It also means that the companies have the ability to meet their obligations in a long term and it is expected to provide and foster the trust of customers and prospective customers of insurance to provide insurance protection.
4. In order to achieve the expected level of profitability (Net Profit Margin), the company must maintain obligations to policyholders, namely by maintaining the level of solvency (RBC). This is indicated by the phenomenon that higher the level of solvency, the higher is the level of profitability (Net Profit Margin). The management of the company should still pay attention to the working capital and liquidity turnover in running its business, even though working capital and liquidity turnover do not affect profitability (Net Profit Margin).
5. In achieving the expected level of profitability (Return on Equity) the management of the companies must improve the efficiency of working capital in order to increase the profitability.

Funding: This study received no specific financial support.

Competing Interests: The authors declare that they have no competing interests.

Contributors/Acknowledgement: Both authors contributed equally to the conception and design of the study.

REFERENCES

- Bawa, S.K. and S. Chattha, 2013. Financial performance of life insurers in Indian insurance industry. *Pacific Business Review International*, 6(5): 44-52.
- Charumathi, B., 2012. On the determinants of profitability of Indian life insurers – an empirical study. *Proceedings of the World Congress on Engineering 2012, WCE*, 1.
- Daare, W.J., 2016. Determinants of non-life insurance companies profitability: An empirical study in India. *International Journal of Innovative Research and Advanced Studies*, 3(13): 6-11.
- Harahap, S.S., 2010. *Critical analysis on financial reporting*. Jakarta: Rajawali Pers.
- Hirt, G.A., S.B. Block and B.R. Danielsen, 2011. *Corporate finance foundations*. 14th Edn., New York: McGraw-Hill Companies, Inc.
- Infobank, 2014. Rating 123 of insurance 2014. *Infobank Magazine No.424*, July 2014, 36.

- Jibran, Q., M. Sameen, A. Kashif and K. Nouman, 2016. Determinants that affect the profitability of non-life insurance companies: Evidence from Pakistan. *Research Journal of Recent Sciences*, 5(4): 6-11.
- Leviyany, T. and S. Wiwin, 2014. The influence of risk based capital to profiability on life insurance companies. *Research Accounting Journal*, 6(1): 1-12.
- MoF, 2004. The healthy of finance of insurance and reinsurance companies. (KMK No. 424/KMK.06/2004). Jakarta.
- Mulyana, B. and E. Elisabeth, 2018. The implication of working capital efficiency, liquidity and solvency to profitability (Case Study at PT. Berdikari Insurance). *Indicators: Scientific & Business Journal*, 2(1): 13-25.
- Rahayu, D. and N. Mubarok, 2017. The influence of risk based capital to profitability at Sharia insurance companies (Case Study on Insurance Companies Listed in AASI). *I-Economic*, 3(2): 189-208.
- Ross, S.A., W.W. Randolph and J.D. Bradford, 2016. *Fundamentals of corporate finance*. 11th Edn., United State of America: McGraw-Hill Education.
- Salombe, A., T.R.E. Johny and S.J. Harry, 2017. Analysis of working capital management a study on PT. Jasa Raharja (Persero) TBK. *Journal of Unsrat Business Administration*, 5(1): 1-5.
- Sawir, A., 2001. *Analysis of financial performance and corporate financial planning*. Jakarta: PT Gramedia Main Library.
- The Ministry of Finance, 2003. *The healthy of finance of insurance and reinsurance companies*. (KMK No. 424/KMK.06/2003). Jakarta.

Views and opinions expressed in this article are the views and opinions of the author(s), The Economics and Finance Letters shall not be responsible or answerable for any loss, damage or liability etc. caused in relation to/arising out of the use of the content.