



## INVESTIGATE OF MECHANICAL FUSE IN CARDAN SHAFT USING FEM

Sayed Poorya Rabiei<sup>1</sup> --- Reza Azarafza<sup>2</sup>

<sup>1</sup>Islamic Azad University, Science and Research Branch, Sanandaj, Iran

<sup>2</sup>Department of mechanical Engineering, Malek Ashtar University of technology, Tehran, Iran

### ABSTRACT

*A Cardan shaft is a mechanical component for transmitting torque and rotation, usually used to connect drive shaft to driven shaft that cannot be connected directly because of distance or the need to allow for relative movement between them. If overload is applied to cardan shaft, failure can occur in each part of the cardan shaft and maybe some irreparable damage occur to the cardan shaft. Thus it is important to investigate the existence of mechanical fuse in cardan shaft, and this subject is analyzed by Abaqus software and the results are illustrated that the cross shaft of an standard cardan shaft, fails first and is the best part as a mechanical fuse.*

**Keywords:** Cardanshaft, Cross shaft, Abaqus, Analysis, Mechanical fuse, Failure.

### 1. INTRODUCTION

The reasons of failures a cardan shaft, while transmitting torque and rotation, are analyzed by some researches. Some of them have done some research on the design of the universal joints. They have offered some helpful suggestions about the configuration design and improvement of universal joints with manufacturing tolerances [1]. Bayrakceken, et al. [2] have done some research about the fracture analysis of a universal joint yoke and a drive shaft that belong in an automobile power transmission system, and they used finite element method for stress analyses that determine stress conditions at the failed section. SirajMohammadAli Sheikh has done some research about analysis of universal coupling under different torque condition [3] using finite element method as stress analysis to determine the stress at the failed section. Mile, et al. [4] have done some research about analysis of the drive shaft fracture of the bucket wheel excavator, and they found out that there are no significant inhomogeneities and errors in the material of the shaft and that they do not cause damage, and significant inhomogeneity of the material,

occurrence of cracks as well as the difference in the microstructure appear in this zone, which is the cause of shaft damage.

Valentin, et al. [5] have done some research about buckling of a twisted and compressed rod supported by Cardan joints, and using numerical integration of a system of ten nonlinear first order differential equations the post-critical shape of the rod was determined. Jeanette Edlund et al. have done some research about effects of two different forwarder steering and transmission drive systems on rut dimensions [6] and they found out that a transmission drive system with axles and wheels that can be individually steered seems advantageous to reduce rut formation, especially if the wheels have reduced ground pressure on soft soils. Danial, et al. [7] have done some research about optimum design of a quasi-homokinetic linkage for motion transmission between orthogonal axes [7] and they mentioned that homokinetic motion transmission between two shafts with axes intersecting at right angles is a recurrent problem, and they came up with a solution with a minimum structural error, but with a slightly compromised transmission quality. Gys and Abdulmohsin Al-Sahli [8] have done some research about failure analysis of conveyor pulley shaft [8] and they mentioned that the shaft of a conveyor belt drive pulley failed in service. In their subject an investigation was performed in order to determine the failure root cause and contribution factors. Investigation methods included visual examination, optical and scanning electron microscope analysis, chemical analysis of the material and mechanical tests. A finite element analysis was also performed to quantify the stress distribution in the shaft and in their research it was concluded that the shaft failed due to fatigue and that the failure was caused by improper reconditioning of the shaft during routine overhaul.

## 2. PROBLEM STATEMENT

Cardan shafts play an important role in industry, and generally they are used for transmitting torque and rotation, and they consist of some components and these components are susceptible to fatigue or failure due to overload or the nature of their operation. Failure can occur in each part of a cardan shaft and maybe because of this failure some irreparable damage occurs to the cardan shaft. In most of former researches, as some of them mentioned in introduction, were not considered that which component of a cardan shaft fails first due to overload and whether mechanical fuse was designed for cardan shaft or not.

Hence we recommend that it is better to find out which part of a cardan shaft fails first and then we will realize whether a cardan shaft has a mechanical fuse or not, and if it does we will find out that this part is the best part that was chosen as a mechanical fuse or not, and raise awareness about behavior of cardan shaft can be great help for designers and consumers.

## 3. ANALYSIS BY EFM METHOD

In this paper, the finite element method is used to gain precise results at critical zones. The analysis by finite element method is more precise than analytic method. The EFM methods

provide possibility of faster repeated calculations after some modifications than analytic method. Thus Abaqus 6.12-1 is used for simulation of cardan shaft failure.

Two different cardan shafts were chosen for analyzing and every single one of them belonged to a different company. The first company [Dana Company \[9\]](#) and the second one [Elbe Company \[10\]](#).

Today, there are basically two types of cardan shafts that have evolved into a worldwide technology standard [9]. Their main difference lied in the design of the bearing eye.

### 3-1. Closed Bearing Eye

This is a design used mainly in the commercial vehicles sector and for general mechanical engineering application, presented at Fig. 1.

### 3-2. Split Bearing Eye

Developed for heavy and super-heavy duty application, presented at Fig. 2.

Fig-1. Closed bearing eye

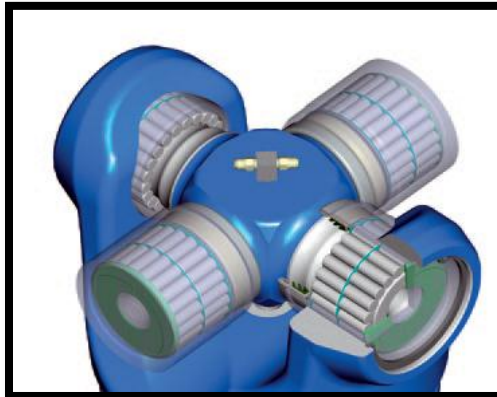
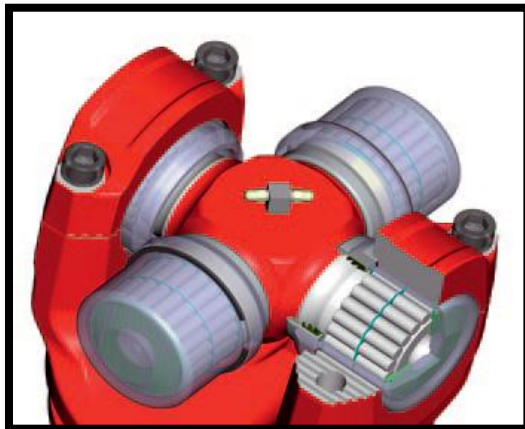

Fig-2. Split bearing eye



The chosen cardan shafts have standard number 687/688.15 and 0.113.100 for Dana and Elbe respectively.

The analysis by EFM method demand following procedure: creating the models; defining the materials and section properties; creating an assembly; defining steps and specifying output requests, since applied loads on cardan shafts in real conditions are dynamic not static, so in this step, dynamic explicit method is employed for solving the problem; defining interactions; prescribing boundary conditions for parts and applied loads, which torsion is applied to the reference points (RP) that are defined on flange yokes that is presented at Fig.3; designing the mesh, creating, running and monitoring the job. In this simulation the maximum torsion force must be applied to the cardan shafts. The maximum torsion force happens when driven shaft is jammed due to some reasons and the drive shaft tries to rotate driven shaft. Thus, in order to simulate this conditon, one of the flange yoke is fixed and then the next end of the cardan shaft that has another flange yoke is rotated until the maximum tension appeared in one of the components, in this way the maxim torsion force will be applied to the cardan shafts, and the part that has the most tension will fail first.

The element types were chosen: Standard, Linear and Tetrahedral. The element sizes were chosen between 0.01m to 0.003m. Applied mesh for Dana and Elbe cardan shafts is presented at Fig.4

**Fig-3.** Applied load to the reference points.

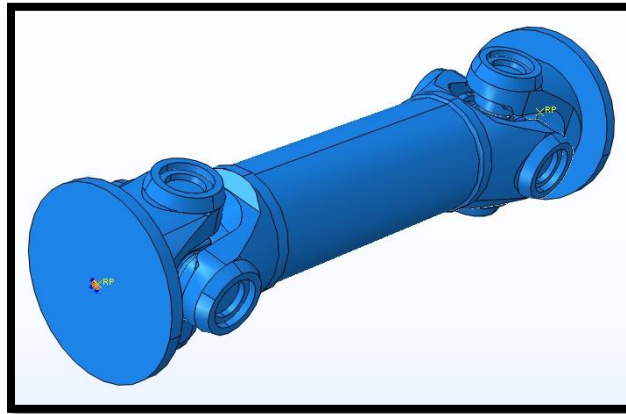

**Fig-4.** Applied mesh for cardan shafts. Dana on the right and Elbe on the left of the picture.

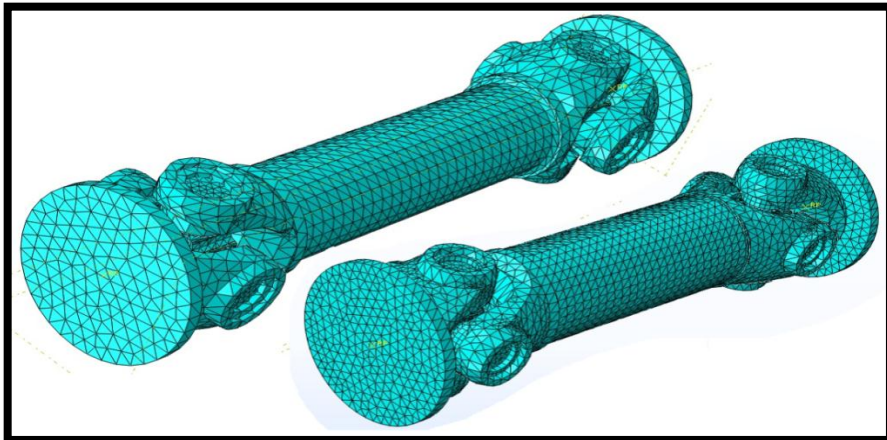

### 3.3. The Results of the Simulations for Cardan Shafts Belonged to Elbe

The results of the simulations for cardan shafts belonged to Elbe are presented at Fig.5, Fig.6 and Fig.7.

At the Fig.5 an assembly of cardan shaft is presented and a cardan shaft which its flange yoke and two bushes are separated and a separated cross shaft from the cardanshaft, are presented at the Fig.6 and Fig.7 respectively. At the presented figures the components are showed with ten deformation scale factor.

The maximum stress due to the torsion at the cross shaft for cardan shaft belongs to Elbe is determined 745.3Mpa. Since a cardan shaft with these materials cannot tolerate this stress at cross shaft, so the cardan shaft will failed at cross shaft.

**Fig-5.** FEM analysis of the cardan shaft belonged to Elbe.

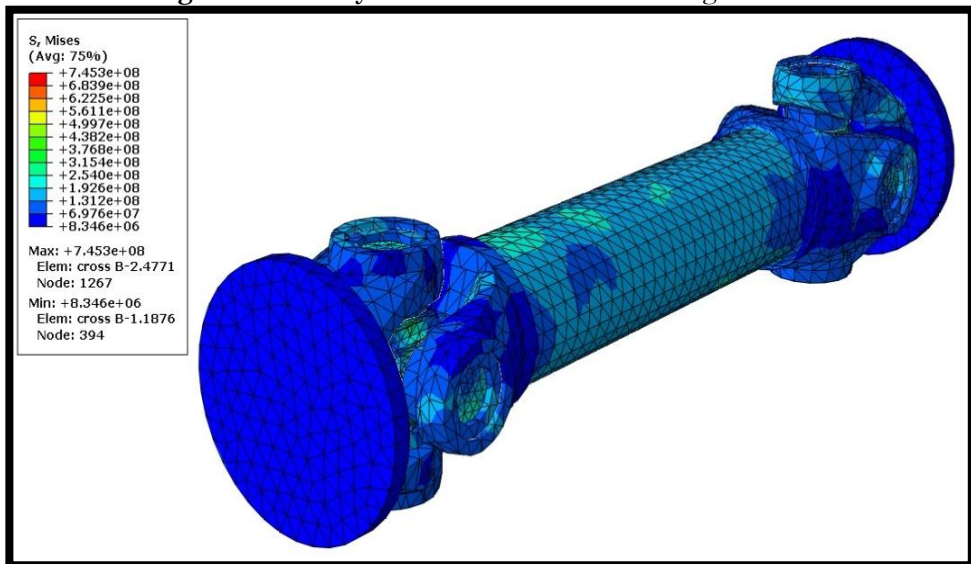

**Fig-6.** FEM analysis of the cardan shaft belonged to Elbe.

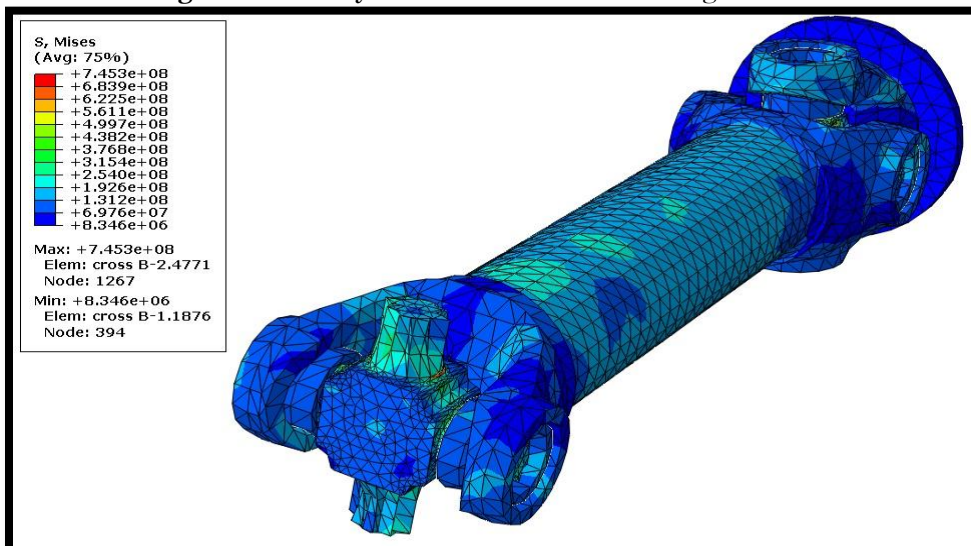
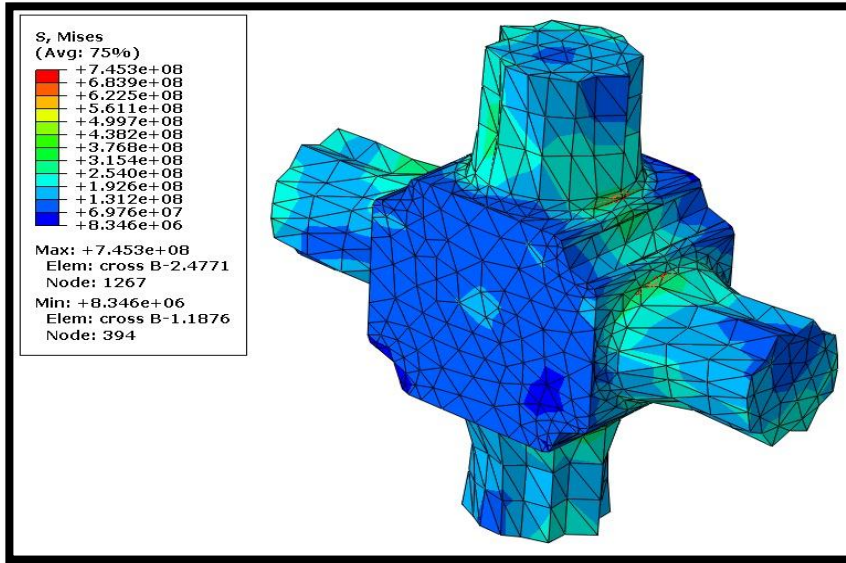

Fig-7. The cross shaft belonged to Elbe.



### 3.4. The Results of the Simulations for Cardan Shafts Belonged to Dana

The results of the simulations for cardan shafts belonged to Dana are presented at Fig.8, Fig.9 and Fig.10.

At the Fig.8 an assembly of cardan shaft is presented and a cardan shaft which its flange yoke and two bushes are separated and a separated cross shaft from the cardanshaft, are presented at the Fig.9 and Fig.10 respectively. At the presented figures the components are showed with ten deformation scale factor.

The maximum stress due to the torsion at the cross shaft for cardan shaft belongs to Dana is determined 791.4Mpa. Since a cardan shaft with these materials cannot tolerate this stress at cross shaft, so the cardan shaft will failed at cross shaft.

Fig-8. FEM analysis of the cardan shaft belonged to Elbe.

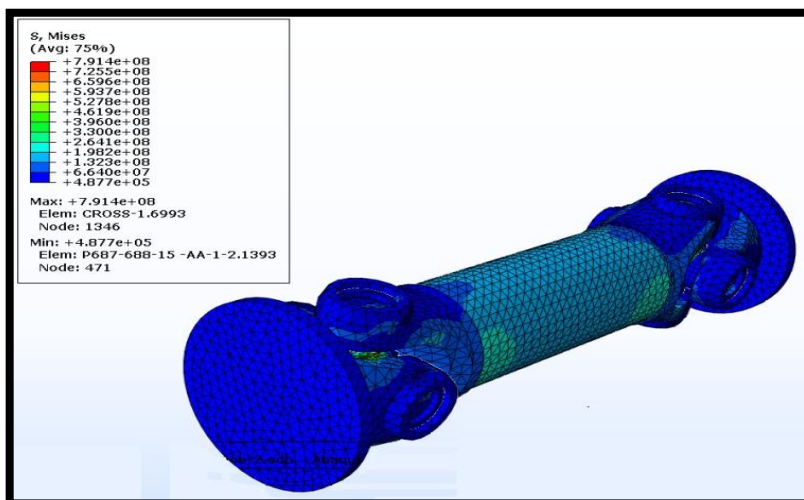

Fig-9. FEM analysis of the cardan shaft belonged to Dana.

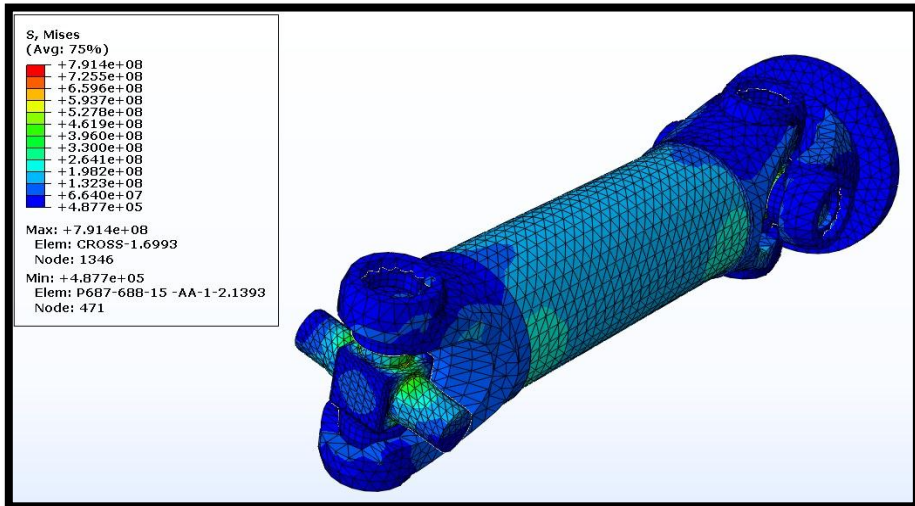
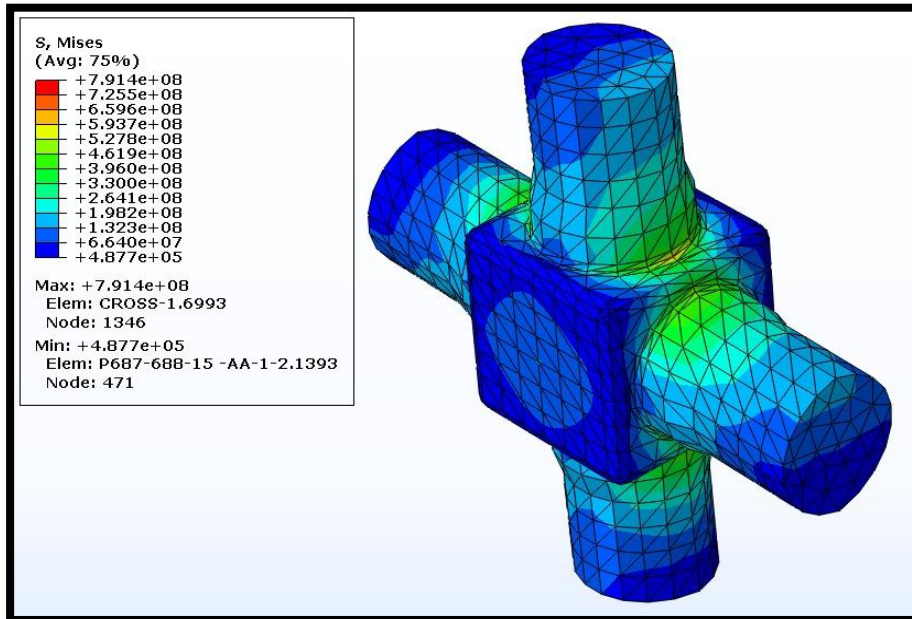

Fig-10. The cross shaft belonged to Dana.



Thus, according to simulation results, the part of a cardan shaft that fails first, due to applied overload is the cross shaft.

#### 4. JUSTIFY SIMULATION RESULTS WITH EXPERIMENTAL SAMPELS

In this part, we are going to justify simulation results with some samples that failed due to overload. Five different cardan shafts were chosen, that four of them belong to Dana company and the other one belongs to Elbe company. All these cardan shafts were used at [Bonab Steel Company \[11\]](#) and all of them failed after over load were applied to them.

As it is illustrated at the following figures, and as it is clear, the part of a cardan shaft that fails first due to applied overload is the cross shaft.

**Fig-11.** A simulated cross shaft and a sample of cross shaft that belongs to Dana, which shows that cardan shaft failed from the cross shaft.

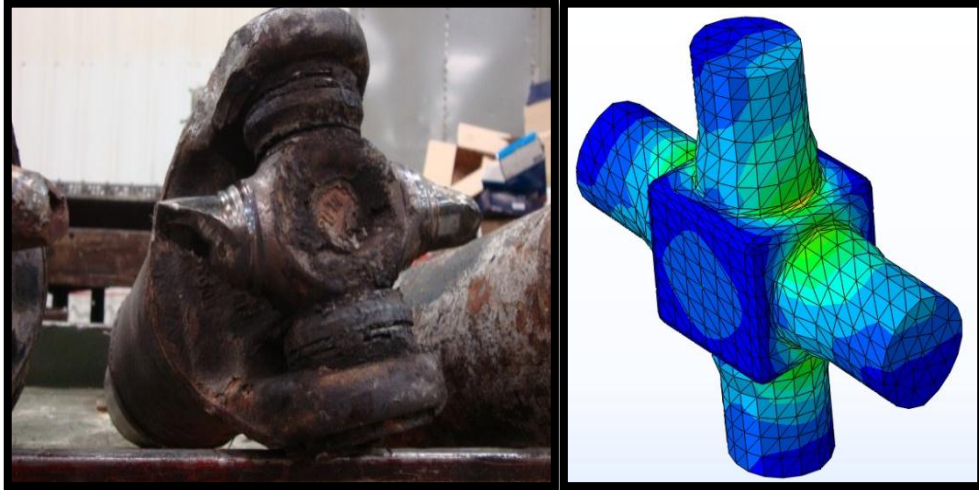

**Fig-12.** Three cardan shafts that belong to Dana and all of them failed at the cross shaft due to overload

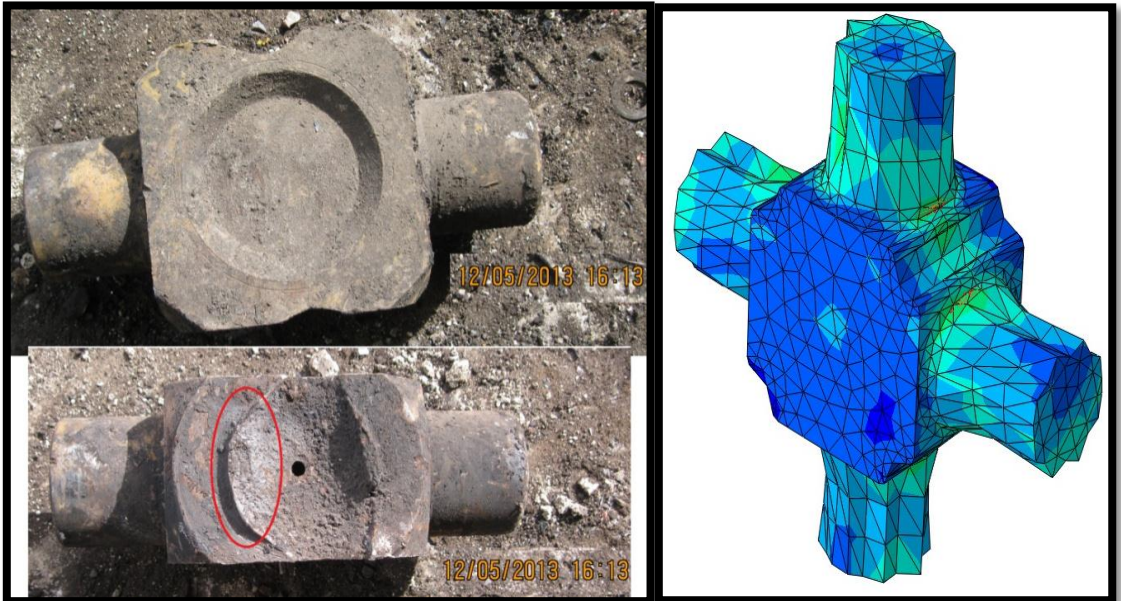

Fig.13 implicates that maximum stress in a cross shaft occur at the basis of the branches of the cross shaft and this fracture zoon, the zoon that fracture starts, is specified with red oval and



justifies the simulation results that cross shaft will fail from the fillet of a cross shaft. In this figure a simulated cross shaft and a sample of cross shaft are presented and both of them show the same result.

**Fig-13.** A simulated cross shaft and a sample of cross shaft that belongs to Elbe.



**Fig-14.** A cardan shaft that belongs to Elbe company that failed at cross shaft.



## 5. CONCLUSION

For some economic and safety aspect, this subject must be perceived that which part of a cardan shaft fails first and whether a cardan shaft has a mechanical fuse or not. A cardan shaft consist of some components and these components are susceptible to fatigue or failure due to

overload or the nature of their operation, and this failure can occur in each part of a cardan shaft and maybe causes some irreparable damage to the cardan shaft or the system. Hence awareness of this subject can be a great help for designers, and they perceive that in some cases they do not have to spend a lot of time and energy on designing a mechanical fuse for their design.

The considerations that are presented in this paper, according to the results of simulation with FEM method and experimental samples, that were presented at parts three and four, indicate that cross shaft fails first due to applied overload. For some economic points of view and other aspects such as repairing expenses and manufacturing cost, the best part of a cardan shaft that can be chosen as mechanical fuse, according to the criteria for choosing mechanical fuse, is the cross shaft and prevent the cardan shaft from some irreparable damage that can occur to the cardan shaft or even worse, to the system. Thus a standardized cardan shaft that is made by an authoritative company has a mechanical fuse.

## REFERENCES

- [1] R. S. Humell and Chassapis, "Configuration design and optimization of universal joints with manufacturing tolerances," *Mechanism and Machine Theory*, vol. 35, pp. 463-476, 2000.
- [2] H. Bayrakceken, S. Tasgetiren, and I. Yavuz, "Two cases of failure in the power transmission system on vehicles: A universal joint yoke and a drive shaft," *Engineering Failure, Analysis*, vol. 14, pp. 716-724, 2007.
- [3] Siraj Mohammad Ali Sheikh, "Analysis of universal coupling under different torque condition," *IJESAT, Mechanical Engineering Department*, vol. 2, pp. 690-694, 2012.
- [4] S. Mile, G. I. Milomir, P. Dragan, A. Z. Neboj, and P. Radmila, "Analysis of the drive shaft fracture of the bucket wheel excavator," *Engineering Failure Analysis*, vol. 20, pp. 105-117, 2012.
- [5] B. G. Valentin, B. M. Ratko, and M. G. Nenad, "Buckling of a twisted and compressed rod supported by cardan joints," *European Journal of Mechanics - A/Solids*, vol. 28, pp. 131-140, 2009.
- [6] E. Jeanette, B. Urban, and L. Bjorn, "Effects of two different forwarder steering and transmission drive systems on rut dimensions," *Journal of Terramechanics*, vol. 49, pp. 291-297, 2012.
- [7] A. Danial, A. Jorge, and N. Scott, "Optimum design of a spherical quasi-homokinetic linkage for motion transmission between orthogonal axes," *Mechanism and Machine Theory*, vol. 59, pp. 107-118, 2013.
- [8] V. Z. Gys and Abdulmohsin Al-Sahli, "Failure analysis of conveyor pulley shaft," *Case Studies in Engineering Failure Analysis*, vol. 1, pp. 144-155, 2013.
- [9] Dana Company.
- [10] Elbe Company.
- [11] Bonab Steel Company, *Bonab steel company*. East Azerbaijan, Iran: Bonab.

*Views and opinions expressed in this article are the views and opinions of the author(s), Review of Information Engineering and Applications shall not be responsible or answerable for any loss, damage or liability etc. caused in relation to/arising out of the use of the content.*